

ALUMA-FORM, INC.



ALUMA-FORM®

Aluma-Form, Inc.

3625 Old Getwell Road
Memphis, TN 38118
P.O. Box 18555 • Memphis, TN 38181-0555
Phone 901-362-0100
Fax 901-794-9515

www.alumaform.com

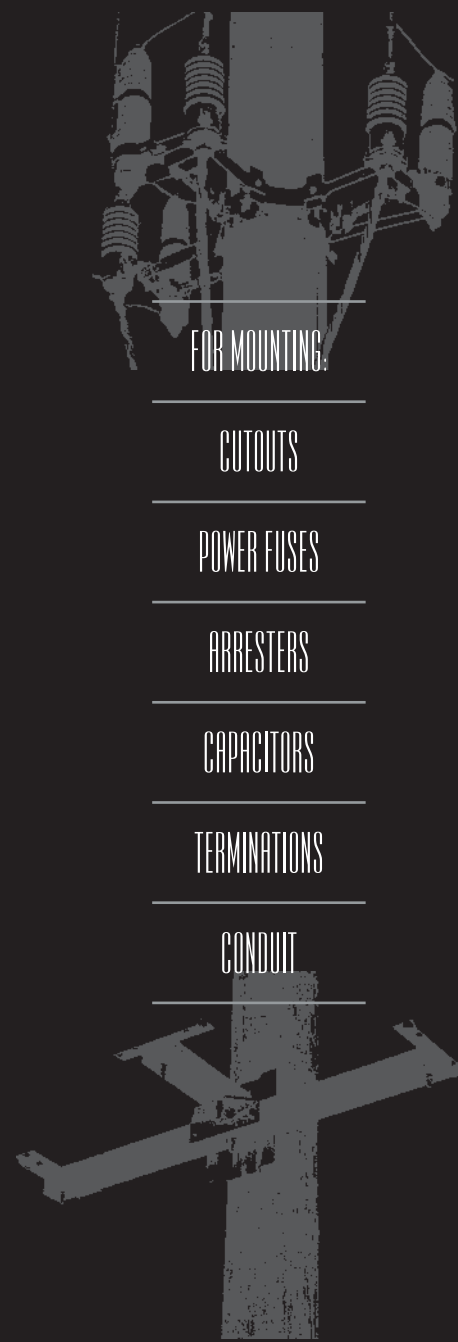

EQUIPMENT MOUNT

ALUMA-FORM, INC.

CATALOG



ALUMA-FORM®



Index

Introduction	3
Typical Installation	4
Aluminum Three Phase Cutout & Arrester Mounts	5
Aluminum Three Phase Disconnect, Termination & Arrester Mounts	6
Bolted Terminator & Arrester Mounts	7
Equipment Mount Accessories	8
Aluminum Single Phase Cutout, Arrester & Terminator Brackets	9
Banded Cutout, Arrester & Terminator Brackets	10
Cable Positioners and Single Phase H.D. Mount for Cutouts, Disconnect Switch & Arresters	11
Intermediate-Station Class Arrester Mounts	12
Conduit Standoff Brackets	13
Cabinet Mounting Brackets & S-Slot Shapes	14
Insulated Wood Equipment Mounts	15
Capacitor Racks	16-17

Important:

This catalog depicts only a small portion of the literally hundreds of specialized mounts we make and offer. If you do not find the bracket you seek, please check with your local representative or call Aluma-Form direct for assistance at 901-362-0100. We solicit special orders.

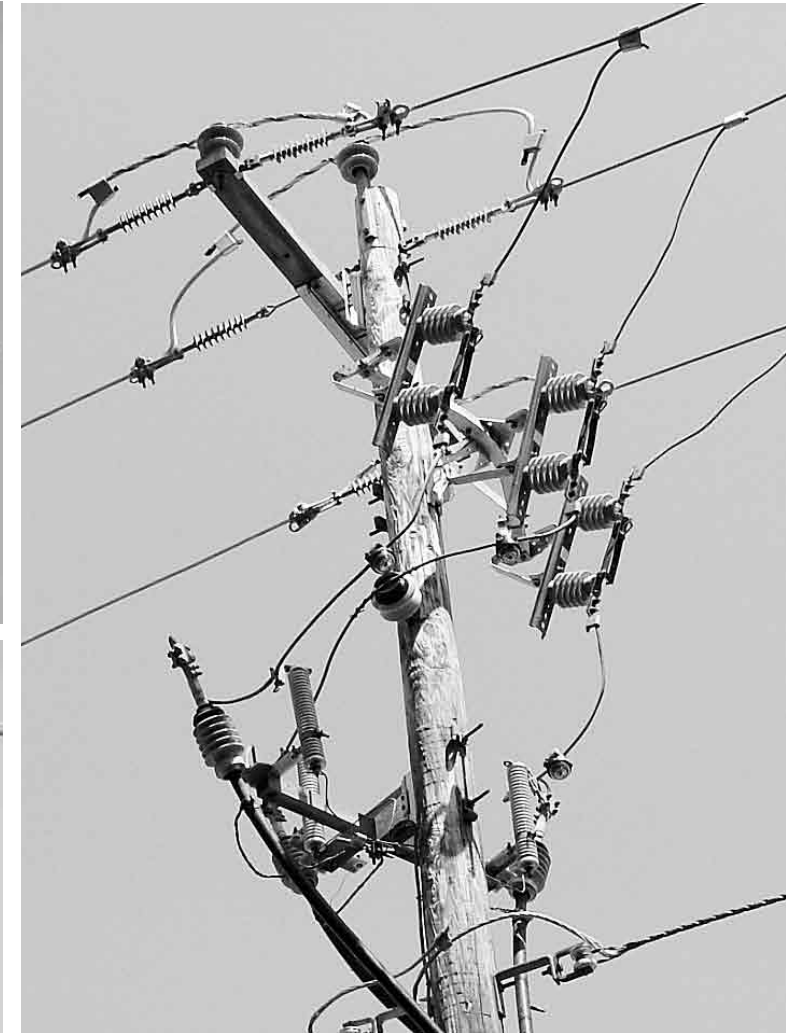
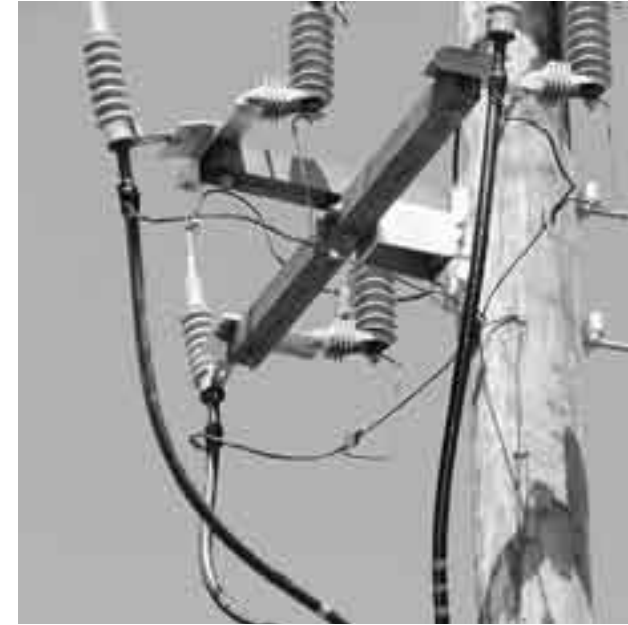

WORLD'S MOST COMPLETE LINE

FOR MOUNTING

- CUTOUTS
- DISCONNECT SWITCHES
- POWER FUSES
- ARRESTERS
- CAPACITORS
- COMBINATION CUTOUT-ARRESTERS
- TERMINATIONS
- FLANGE TERMINATIONS
- SUPPORTING CABLE
- SUPPORTING CONDUIT
- ELBOW SWITCHING STAND

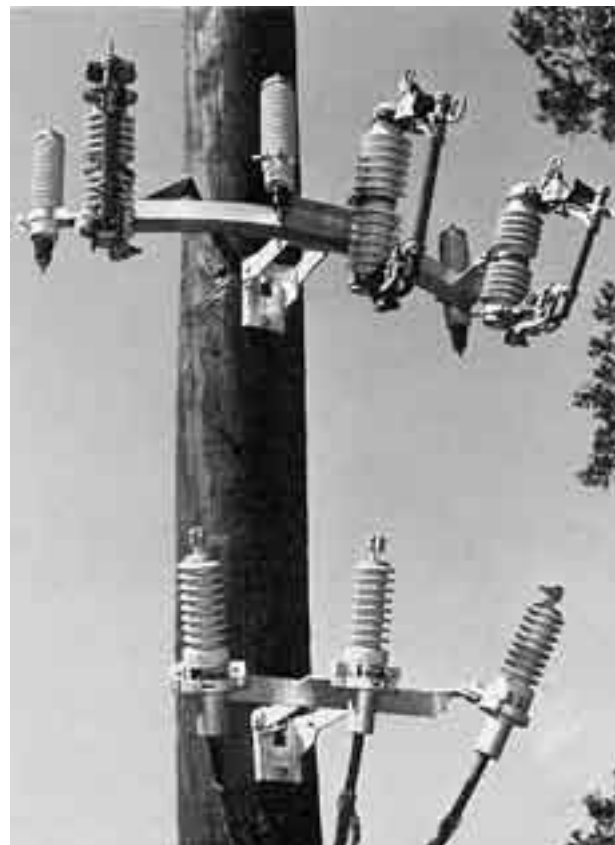
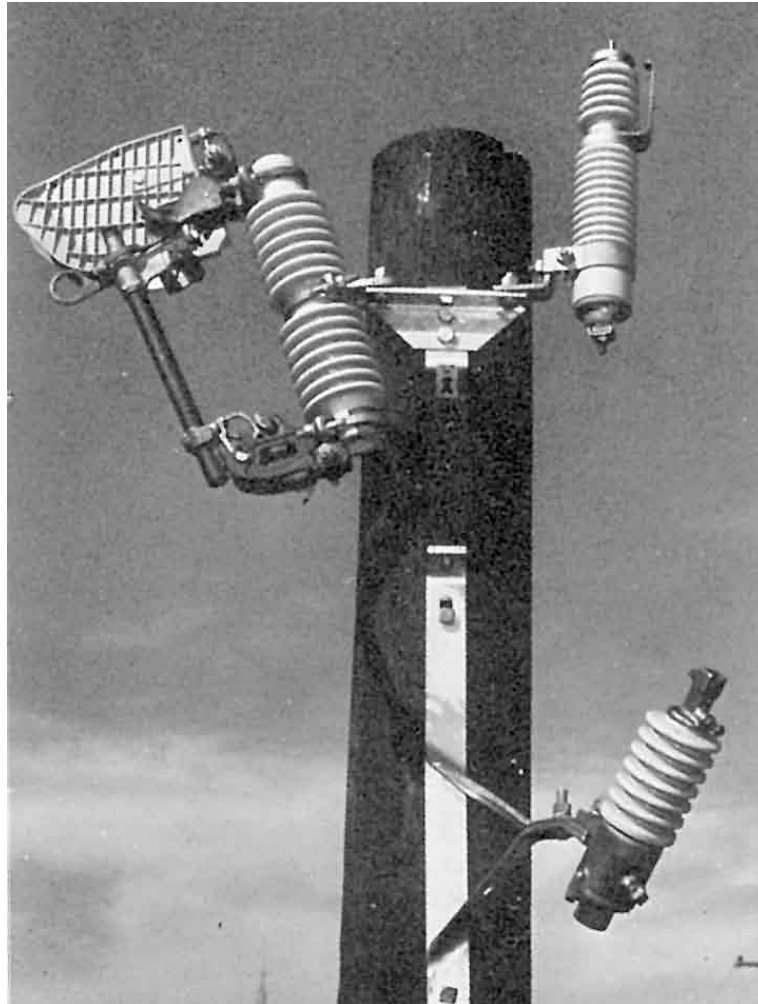
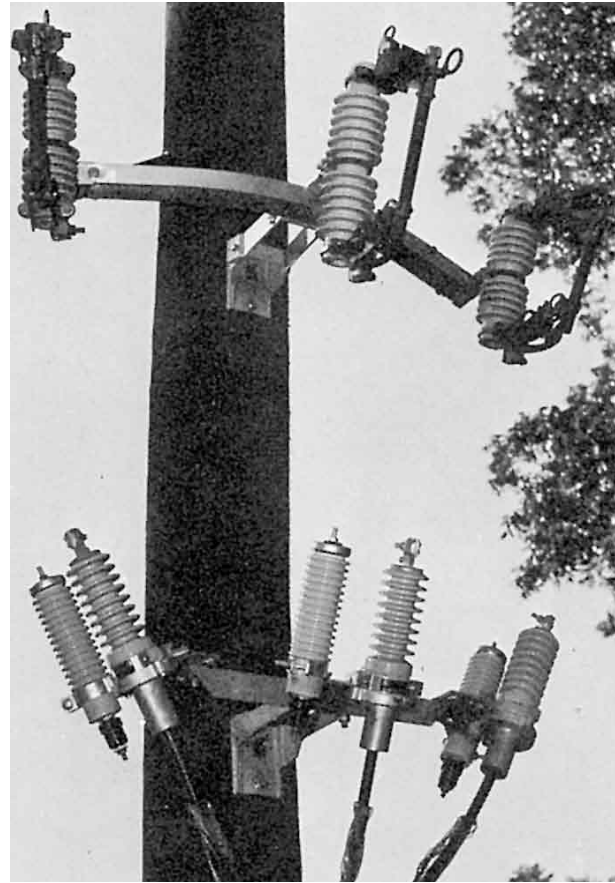

FOR THRU-BOLT MOUNTING



MODELS #R3CA AND R3CA-48

For mounting cutouts, arresters or terminations. Strong torsion-resistant mount to receive 6 pieces of equipment. Mounts on wood poles with 5/8" thru-bolt and 3 lag screws (not furnished). Each mounting position of Model R3CA tested, without braces to 250 pounds with a safety factor of 2. Braces offer extra strength and rigidity to assist lineman in opening and closing cutouts. Grounding device supplied.

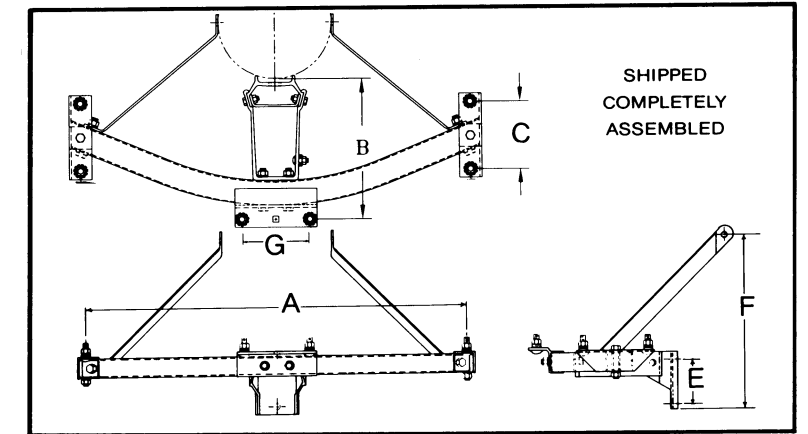

MODELS #R3CA-C AND R3CA-C-48

Identical to above except that end fittings permit the mounting of combination cutout-lightning arrester units, terminations- or single cutouts that require only one bolt for mounting. Mounts 3 pieces of equipment.

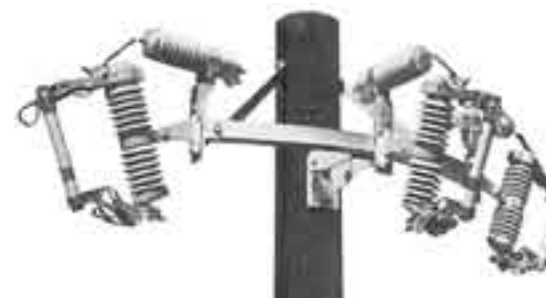
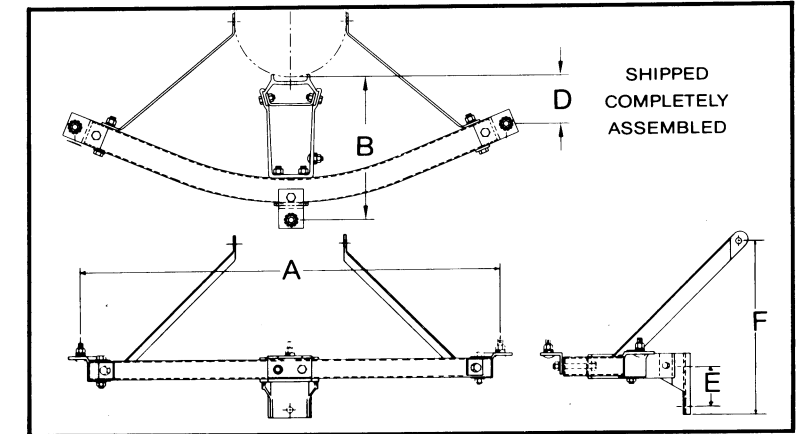

MODELS #R3CA-2C AND R3CA-2C-48

Same as above except that end fittings are designed to hold 3 combination cutout-lightning arrester units that require 2 bolts for mounting. Also mounts NEMA L bracket.

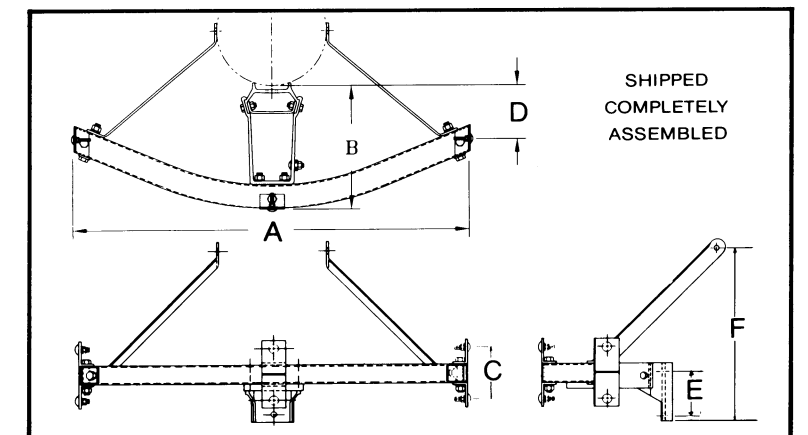

Catalog No.	Product No.	A	B	C	D	E	F	G
R3CA	51839	34 ¹ / ₂ "	12 ¹ / ₄ "	6"	-	3 ⁵ / ₈ "	±19"	6"
R3CA-C	51840	38 ⁵ / ₈ "	12 ⁷ / ₈ "	-	4 ³ / ₈ "	3 ⁵ / ₈ "	±19"	-
* R3CA-2C	51841	36 ³ / ₁₆ "	11 ⁵ / ₁₆ "	47 ¹ / ₁₆ "-5 ³ / ₁₆ "	47 ⁷ / ₈ "	3 ⁵ / ₈ "	±19"	-
R3CA-48	51842	48"	15"	10"	-	3 ⁵ / ₈ "	±19"	10"
R3CA-C-48	51843	52 ¹ / ₄ "	12 ⁷ / ₈ "	-	17 ¹ / ₁₆ "	3 ⁵ / ₈ "	±19"	-
* R3CA-2C-48	51844	49 ¹³ / ₁₆ "	11 ⁵ / ₁₆ "	47 ¹ / ₁₆ "-5 ³ / ₁₆ "	11 ⁵ / ₁₆ "	3 ⁵ / ₈ "	±19"	-

*C Dimension adjustable

TO ORDER UNITS WITHOUT BRACES ADD LB TO CAT. NO.

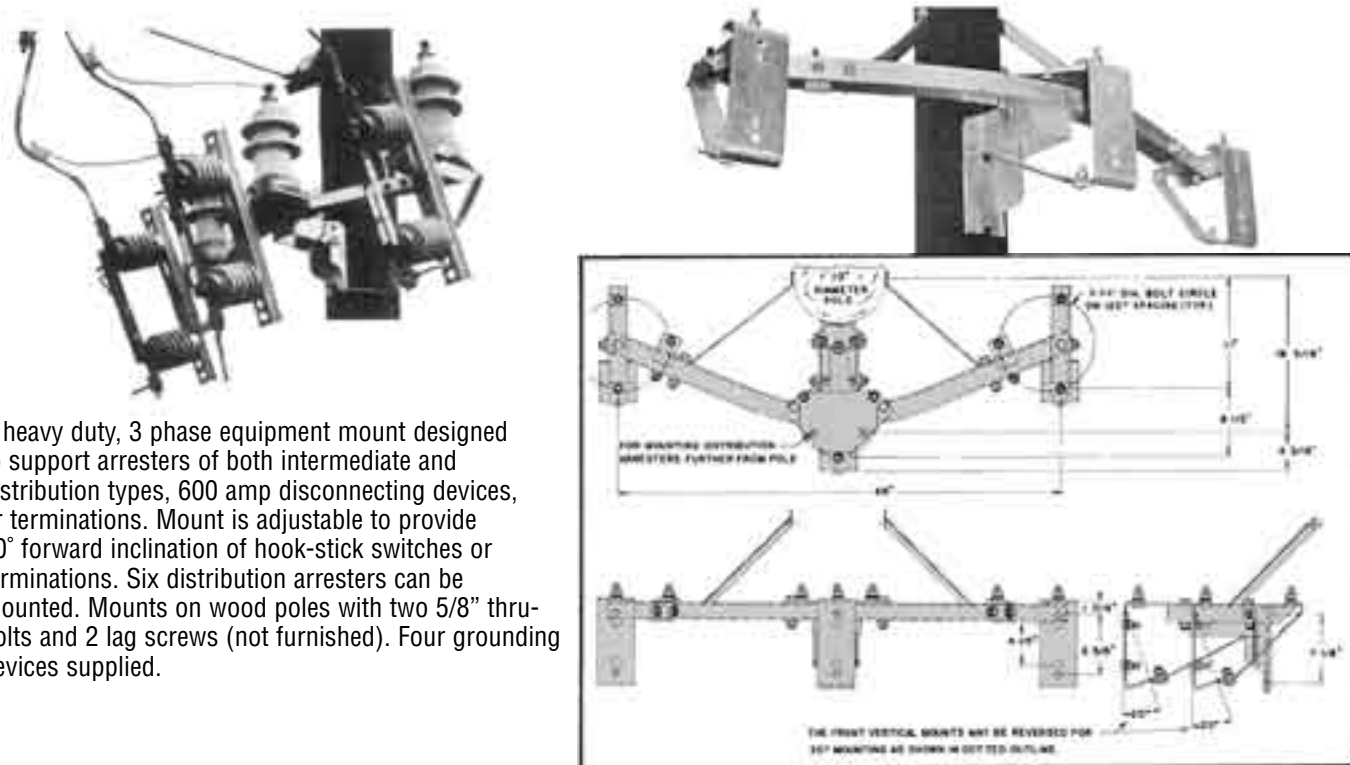

A heavy duty, 3 phase equipment mount designed to support arresters of both intermediate and distribution types, 600 amp disconnecting devices, or terminations. Mount is adjustable to provide 20° forward inclination of hook-stick switches or terminations. Six distribution arresters can be mounted. Mounts on wood poles with two 5/8" thru-bolts and 2 lag screws (not furnished). Four grounding devices supplied.

Mounts with 5/8" thru-bolt and 1/2" lag screw (not supplied). Equipment mounting hardware and grounding device included.

Three Phase Terminator Mounts

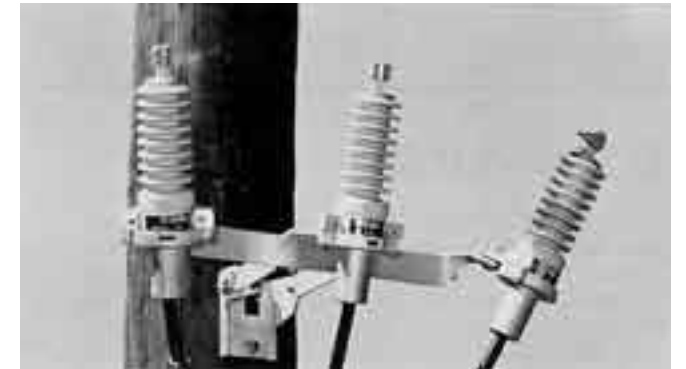
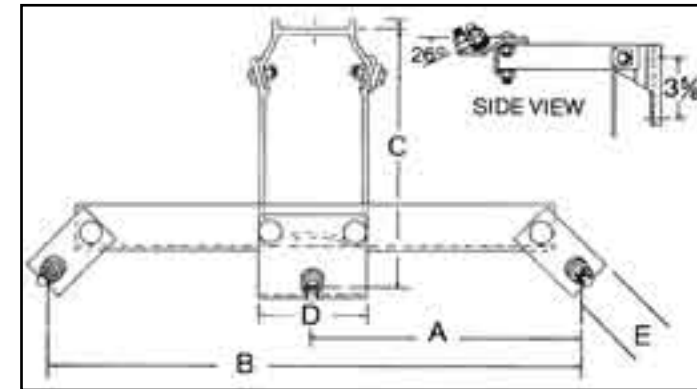

26° ANGLE STANDARD, ALSO AVAILABLE WITH 0° ANGLE (ADD SUFFIX STR FOR 0° ANGLE)

Catalog No.	Product No.	A	B	C	D	E
TB-EMB-13PA	51033	11 ⁵ / ₈ "	23 ¹ / ₄ "	11"	4 ¹³ / ₁₆ "	2"
TB-EMB-1-3PA-35	51063	16 ³ / ₄ "	33 ¹ / ₂ "	11"	4 ¹³ / ₁₆ "	2"

3-Phase Brackets for Mounting Arresters and Flange Mounted Terminations

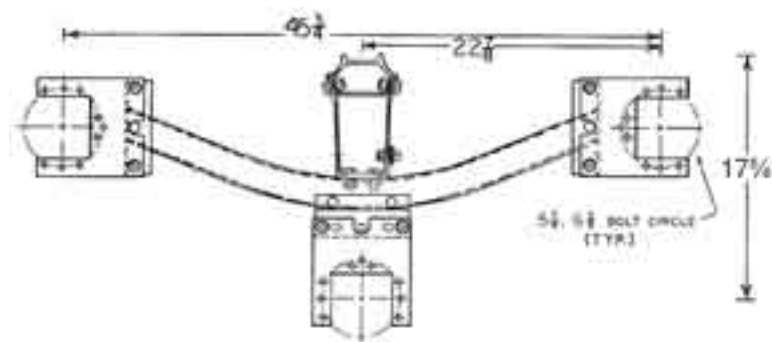

MODEL #R3CA-LB-3FMP
PRODUCT # 51860
For mounting three flange mounted terminations (20° angle). Distribution arresters may be mounted adjacent to terminations, if desired. Mounts with 5/8" thru-bolt and 1/2" lag screw (not supplied) on 3⁵/₈" centers. Grounding device supplied.

Three Phase Terminator-Arrester Mounts

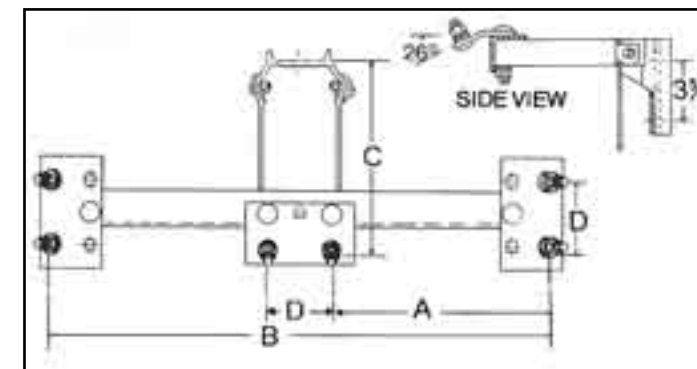

26° ANGLE STANDARD, ALSO AVAILABLE WITH 0° ANGLE (ADD SUFFIX STR FOR 0° ANGLE)

Catalog No.	Product No.	A	B	C	D
TB-EMB-1-6PA	51837	10 ⁹ / ₁₆ "	24 ³ / ₄ "	11"	3 ⁹ / ₁₆ "
TB-EMB-1-6PA-35	51064	15 ¹¹ / ₁₆ "	35"	11"	3 ⁹ / ₁₆ "

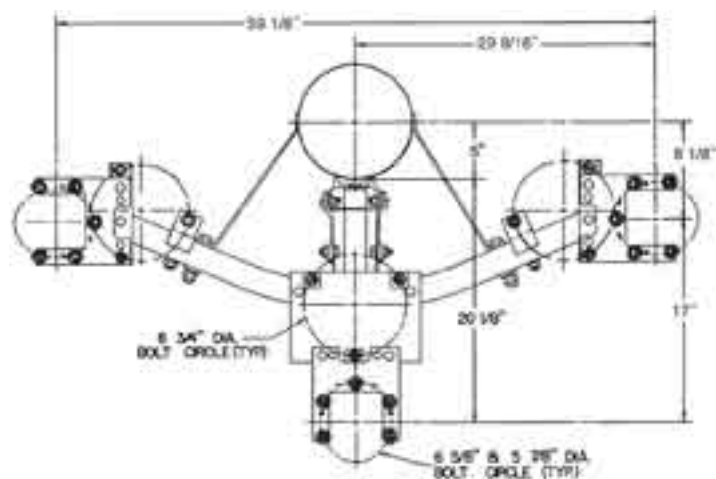

MODEL #R3A-3FMP
PRODUCT # 51870
Mounts three intermediate lightning arresters and three flange mounted terminations (20° angle). All arrester and termination mounting hardware is supplied. Mounts with two 5/8" thru-bolts on 7" centers (not supplied). Grounding device supplied.

Structo-Tube Extension

Extruded rectangular tube for strength and torque resistance. Allows more climbing space, greater clearance distance from pole. Fits snugly over end of all EMB mounts for maximum strength of 150 lbs. with safety factor of 4, 23" from pole surface.



Model #ST-23W/B
Product #51864

Extension Plate

To provide additional spacing between equipment and increased clearance distance from pole. Complete with bolts. Slotted holes in 5/16" thick plate are to permit use on any equipment mount or on the Structo-Tube Extension. Mounting bolts are included and held in place by a retainer to permit one-hand installation by lineman.

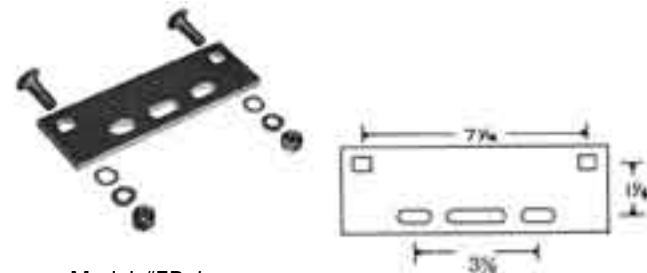

Model #EP-1
Product #51807

Cable Terminator or Termination Mounts

3-position and 1-position terminator brackets for mounting terminations and cable terminators. Fits EMB series-or-thru-bolt Model TB-EMB-1. Mounting posts are angled 26° to provide easier cable training and open wire clearance. Mounting bolts are included and held in place by a retainer to permit one-hand installation by lineman.

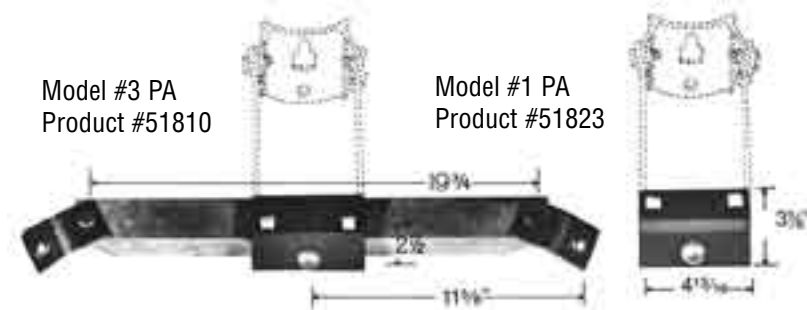

Model #3 PA
Product #51810

Model #1 PA
Product #51823

Cable Terminator-Arrester Mounts

6-position and 2-position brackets for mounting an arrester beside the cable terminator, otherwise same as above.

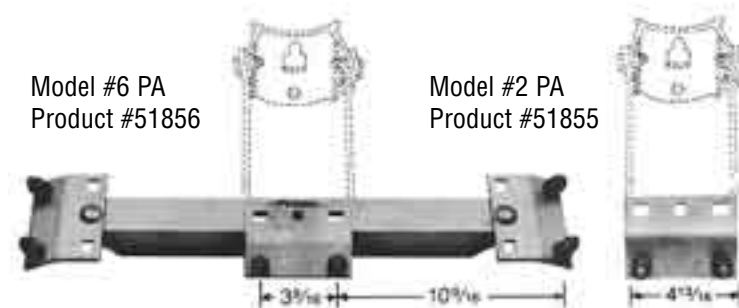

Model #6 PA
Product #51856

Model #2 PA
Product #51855

For Distribution Cutouts, Arresters and Terminations

Thru-bolt mounting. Each bracket load tested to 500 lbs. with a safety factor of 2.

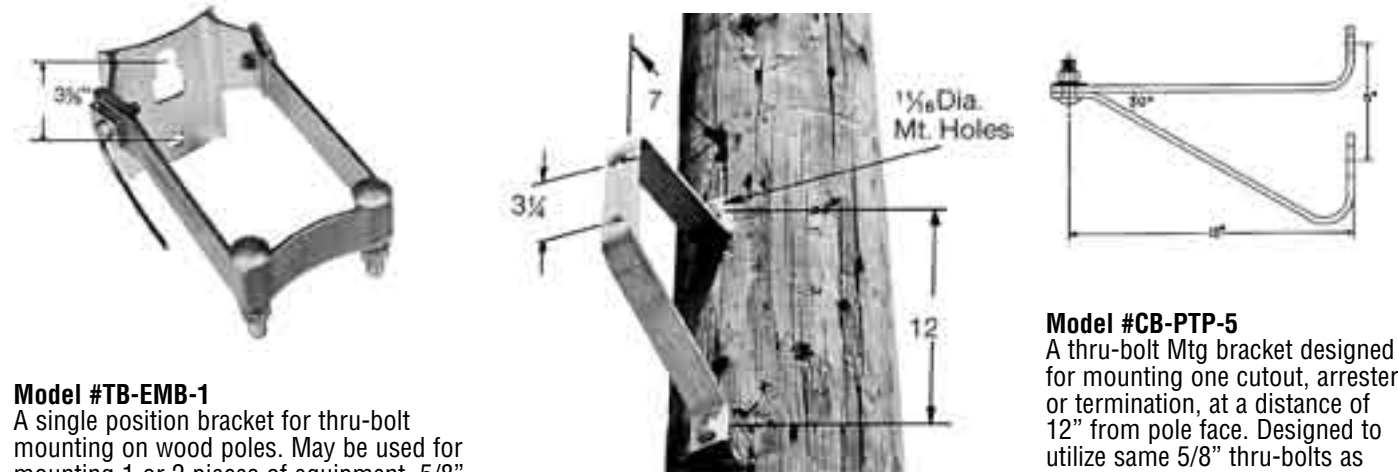

Model #TB-EMB-1

A single position bracket for thru-bolt mounting on wood poles. May be used for mounting 1 or 2 pieces of equipment, 5/8" thru-bolt recommended for installation. 5" high back plate is drilled to receive 1/2" lag screw. Two brackets may be mounted back-to-back on same thru-bolt. Bracket may be used with several accessories as shown on page 8. #4 solid aluminum pigtail provided for ground connection.

Model #CB-1

For installing single cutouts, lightning arresters, or terminations. Standard NEMA "L" type bracket mounts directly to the Model #CB-1. Unit mounts to pole with 2 thru-bolts (not furnished). Two units may be mounted back to back on same thru-bolts.

Model #CB-PTP-5

A thru-bolt Mtg bracket designed for mounting one cutout, arrester or termination, at a distance of 12" from pole face. Designed to utilize same 5/8" thru-bolts as pole top pin.

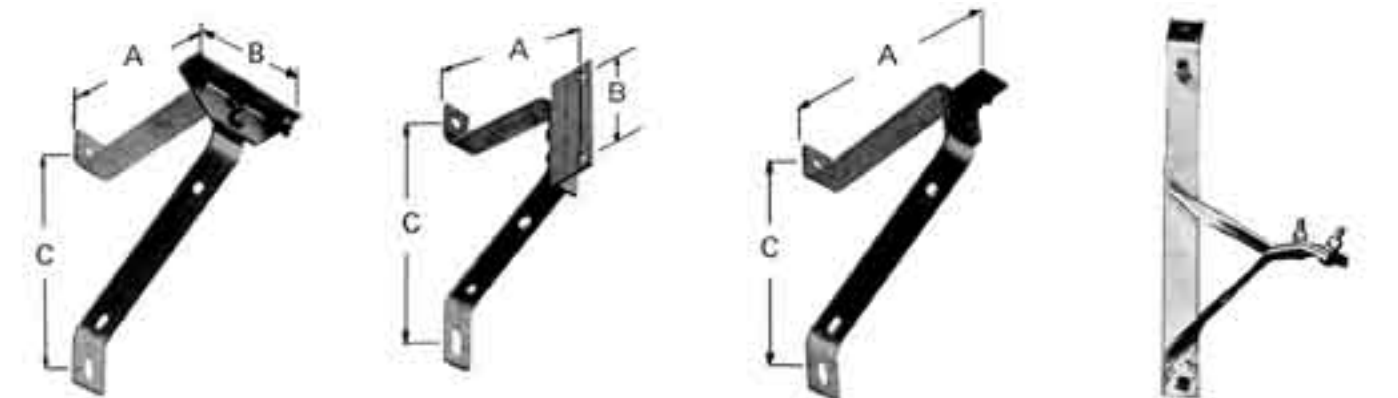

Model #1HCA & 1HCA-18

For mounting individual cutouts and arresters.

Model #1HCA-2C & 1HCA-2C-18

For mounting combination cut-out-lightning arrester or L brackets that require 2 bolts to mount.

Model #1HCA-C & 1HCA-C-18

For mounting single cut-outs or combination cutout-lightning arrester units requiring only 1 bolt to mount.

Model #1PB

May be added to models shown at left. Offset 45° to provide increased clearance.

All units mount with 5/8" thru-bolts (not supplied)

Dimensions				
Catalog No.	Product No.	A	B	C
1HCA	51040	12 ³ / ₈ "	6"	15 ³ / ₁₆ "
1HCA-18	51056	17"	10"	18"
1HCA-1PB	51054	12 ³ / ₈ "	6"	15 ³ / ₁₆ "
1HCA-18-1PB	51060	17"	10"	18"
1HCA-2C	51042	14 ³ / ₈ "	4 ¹ / ₄ "	15 ³ / ₁₆ "
1HCA-2C-18	51051	18"	4 ¹ / ₄ "	18"
1HCA-2C-18-1PB	51061	14 ³ / ₈ "	4 ¹ / ₄ "	15 ³ / ₁₆ "
1HCA-2C-1PB	51154	18"	4 ¹ / ₄ "	18"
1HCA-C	51041	13 ³ / ₈ "	-	15 ³ / ₁₆ "
1HCA-C-18	51055	18"	-	18"
1HCA-C-1PB	51045	13 ³ / ₈ "	-	15 ³ / ₁₆ "
1HCA-C-18-1PB	51155	18"	-	18"

Note: All 1HCA models can be ordered with 1PB accessory by adding -1PB to the appropriate catalog number.

For Cutouts, Arresters, and Terminations

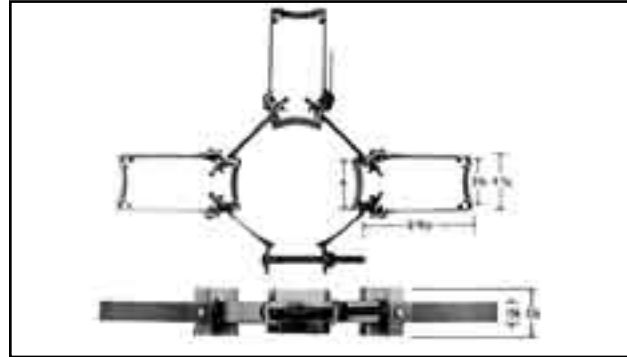

For armless mounting of up to 6 pieces of equipment. Each mounting position load tested to 600 lbs. with a safety factor of 2. Factory pre-assembled into 1 piece and ready for installation. Spring locking clip that permits instant adjustment to perfect fit on 7³/₄" to 12¹/₄" round metal, concrete

or wood poles. Same proven banded principals as featured on Aluma-Form transformer clusters. #4 solid aluminum pigtail provided for ground connection. Mounting bolts included as shown.



Model #EMB-32
Product # 51006



Model #EMB-2
Product # 51005



Model #EMB-1
Product # 51004

Model #FMP Bent Adapter Plates Product #51847

For Flange mounted termination. Plates fit on EMB series and Models #TB-EMB-1, R3CA, 1HCA, R3CA-48, and 1HCA-18. 5 mounting bolts with nuts are included with each plate.

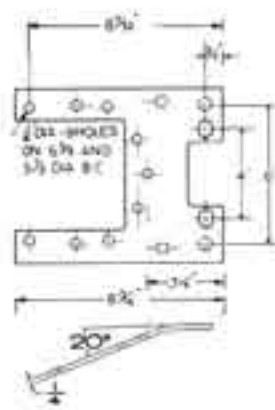

Model #FMP STR Adapter Plate Product #51881

Straight adapter plate fits same equipment as #FMP.



Cable Positioners



Model CS-820
Product #51919



Installed Unit



Model CS-819
Product #51897

Standard Cartons Consist of 36 units.

Easily installed units consist of an aluminum saddle, a polyethylene foam double coated bonding tape with pressure sensitive synthetic polymer (rubber based) adhesive, and a helically cut polyethylene cable tie. Model CS-819 and Model CS-820 universally accept outside cable diameters from 3/4" to 3" (19mm to 76mm).

Single Phase Heavy Duty Mount

Model #1CSA Product #51929

A single phase bracket with features identical to our R3CSA-48 shown on page 6. Shipped assembled as shown in photo. Mounts on pole with two 5/8" thru-bolts (not furnished) on 7¹/₈" centers. Grounding device supplied.



Double arrester protection for an underground circuit mounted on a Model 1CSA equipment mount. Cutout can be mounted as shown or plate can be turned 180° to permit cutout to be mounted on a 20° angle for easier wiring.

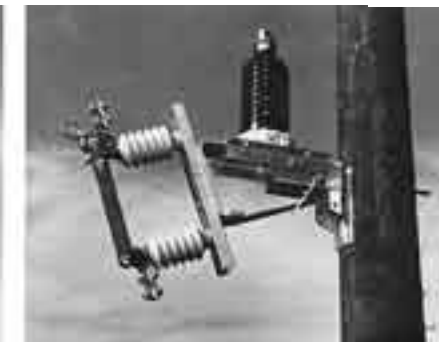

An intermediate arrester and a disconnect switch mounted on a Model 1CSA equipment mount. Note plate that holds switch is mounted on a 20° angle to permit easy opening and closing.



An intermediate arrester and a cutout mounted on a Model 1CSA equipment mount.

Intermediate Arrester Brackets



Model #WBMA-1
Product #51832

An economical mount that requires a minimum of vertical pole space. Plate is bent to permit arrester to tilt up to 5°. Mounts with two 5/8" thru-bolts (not furnished) on 6 5/8" centers.



Model #WBMA-3
Product #51833

Permits three intermediate arresters with 8 3/4" bolt circle to be banded on round metal, concrete or wood poles. Identical proven banding feature as on EMB equipment mount line for instant perfect fit on a 7 3/4" to 12 1/4" diameter pole.

Banded Heavy Duty Arrester Mount

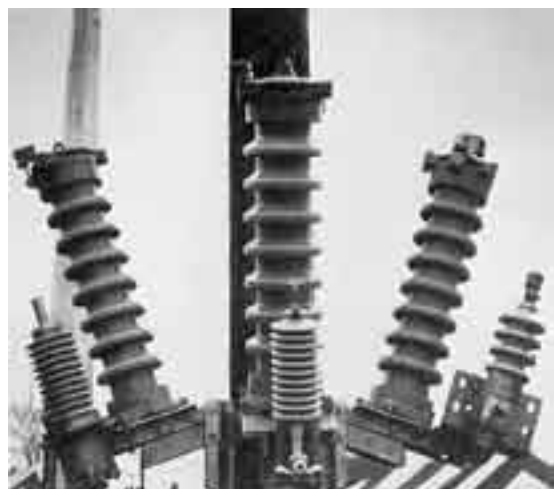

A heavy duty, 3-phase equipment mount designed to support intermediate arresters, fuse cutouts and/or any type of termination (as shown). This unit mounts any intermediate-station class arrester up to 72 KV with 8 3/4" bolt circle mounting. The 3IAP is designed with an angular tilt to maintain more than sufficient clearance for phase to phase and phase to ground spacing. Fits pole range 7 3/4" to 12 1/4". By removing the bands, three single position thru-bolt brackets are available for either single phase or in-line construction.

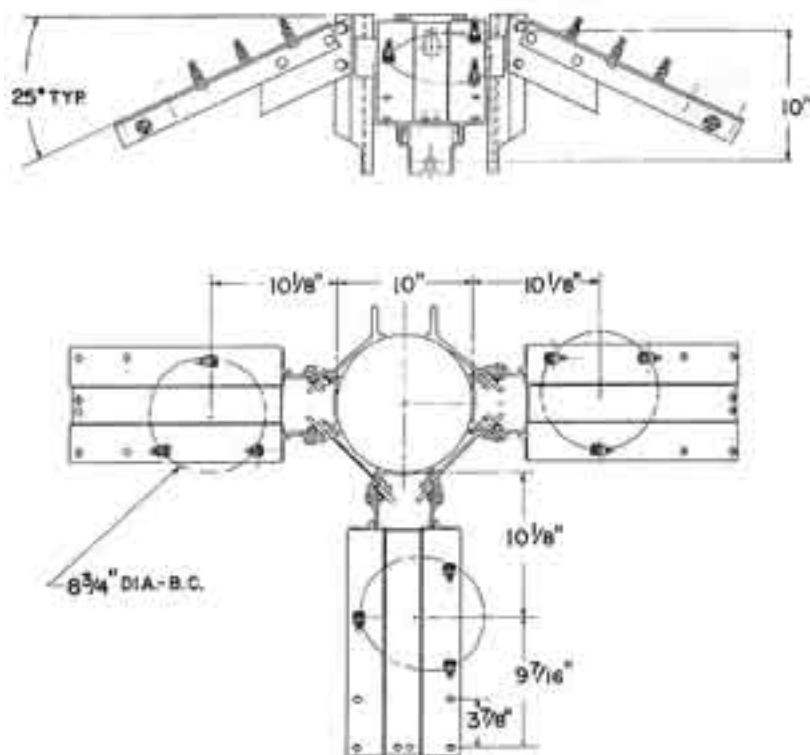

A multi-purpose bracket for mounting 1" thru 6" conduit in a variety of ways. This bracket will mount up to six 6" conduit with infinite adjustability. 4 way T-Slot extrusion eliminates field drilling. Mounts to the pole on 3 5/8" hole centers with 5/8" thru bolt and 1/2" lag screws (not supplied)

Catalog Number	Product	Weight	Dimensional Data	
			A	B
6-CSO-12	51961	4 lbs.	6"	12"
6-CSO-24	51962	5 lbs.	6"	24"
6-CSO-36	51963	6 lbs.	6"	36"
9-CSO-12	51964	4 lbs.	6"	12"
9-CSO-24	51965	5 lbs.	6"	24"
9-CSO-36	51966	6 lbs.	6"	36"

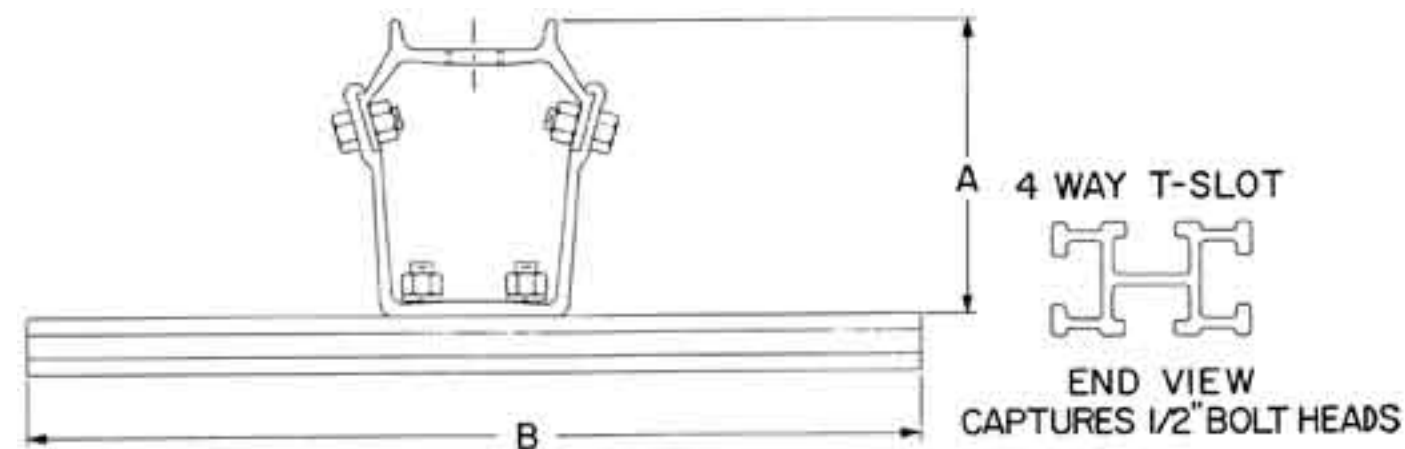

Strap kits are available for use with the CSO system with the following variations. The straps have two holes and strap kit consists of straps, bolts, nuts, and washers for mounting one conduit section. These units can also be used with Bolt-A-Band systems to attach to steel or concrete. Contact your representative for adjustable units.

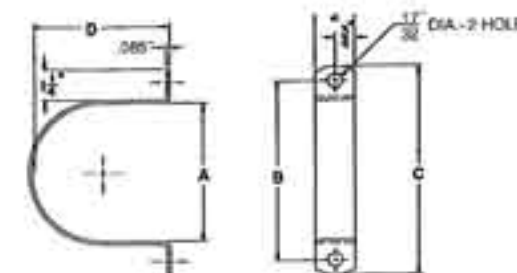

Description	Catalog No.	Product No.	Weight	A dimension	B dimension	C dimension	D dimension
2 Inch	STK-2	51967	.5 lbs.	2 3/8"	3 31/32"	5 3/32"	2 1/4"
2 1/2 Inch	STK-2.5	51968	.6 lbs.	2 7/8"	4 15/32"	5 19/32"	2 3/4"
3 Inch	STK-3	51969	.6 lbs.	3 1/2"	5 3/32"	6 7/32"	3 3/8"
3 1/2 Inch	STK-3.5	51970	.6 lbs.	4"	5 19/32"	6 23/32"	3 7/8"
4 Inch	STK-4	51971	.6 lbs.	4 1/2"	6 3/32"	7 7/32"	4 3/8"
5 Inch	STK-5	51972	.7 lbs.	5 9/16"	7 5/32"	8 9/32"	5 1/16"
6 Inch	STK-6	51973	.7 lbs.	6 5/8"	8 7/32"	9 11/32"	6 1/2"

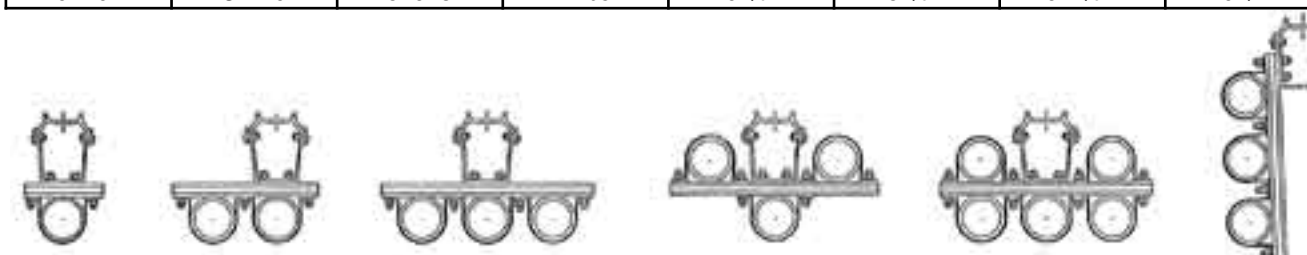

Multi-Purpose Cabinet Mounting Brackets

Aluma-Form T-Slot multi-purpose cabinet mounting brackets for meter cabinets, meter sockets, or other light duty enclosures. These units are designed for mounting to poles or walls.

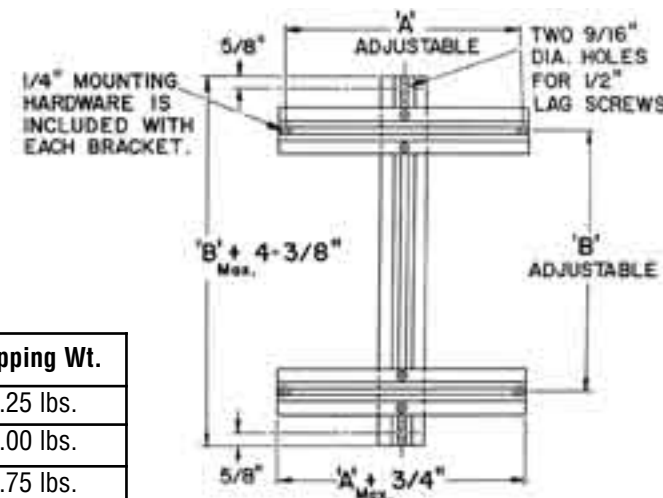
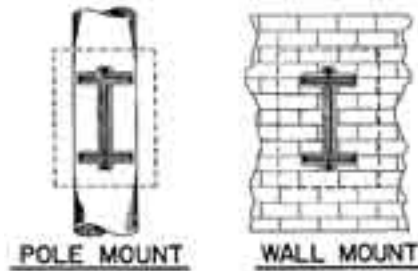

Catalog No.	Product No.	Mounting Range A	Mounting Range B	Shipping Wt.
CMB-8-12	51943	1" to 7 1/4"	2" to 12"	2.25 lbs.
CMB-12-18	51944	1" to 11 1/4"	2" to 18"	3.00 lbs.
CMB-16-24	51945	1" to 15 1/4"	2" to 24"	3.75 lbs.
CMB-18-30	51946	1" to 17 1/4"	2" to 30"	4.25 lbs.

Note: These brackets are shipped "knocked down."
Other ranges of dimensions 'A' and/or 'B' may be special ordered.

T-Slot Shapes

Aluma-Form "T-Slot" shapes for versatile equipment mounting. These custom shapes are extruded from high strength, heat treated 6061-T6 aluminum alloy.

4-Way T-Slot

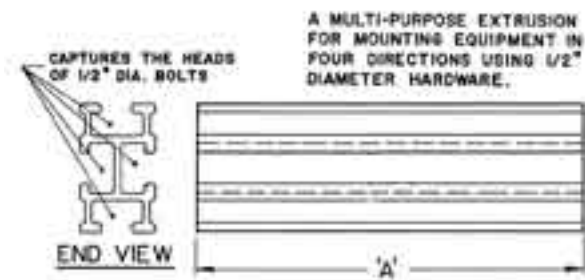

Catalog No.	Part No.	Dimension A	Weight Lbs.
4WT-12	13244	12"	1.25
4WT-24	13249	24"	2.25
4WT-36	13250	36"	3.25
4WT-48	13284	48"	4.50
4WT-60	13315	60"	5.50
4WT-120	13285	120"	11.0

2-Way T-Slot

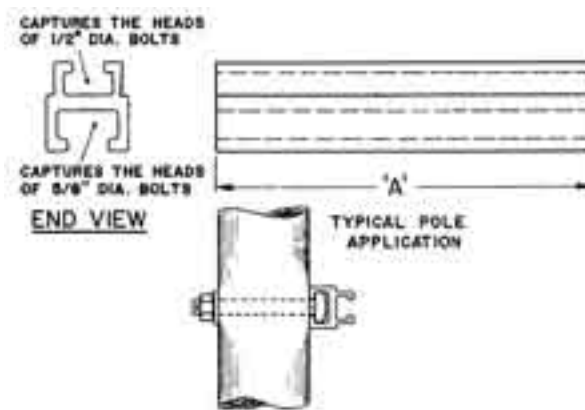

Catalog No.	Part No.	Dimension A	Weight Lbs.
2WT-12	01501	12"	1
2WT-24	01502	24"	2
2WT-36	01503	36"	3
2WT-48	01504	48"	4
2WT-60	01505	60"	5
2WT-120	01506	120"	10

NOTE: Both the extrusions can be used for thru-bolt mounting equipment to poles, structures, walls, enclosures, machinery, etc. Other lengths are available on a special order basis, contact the factory for details

FOR MOUNTING: CUTOUTS & ARRESTERS/TERMINATIONS & ARRESTERS

Models #W3CA-35 & W3CA-48

For mounting six pieces of equipment. Potheads, arresters or cutouts. Mounts with two 5/8" thru bolts (not supplied) Comes complete with equipment mounting hardware and grounding device.

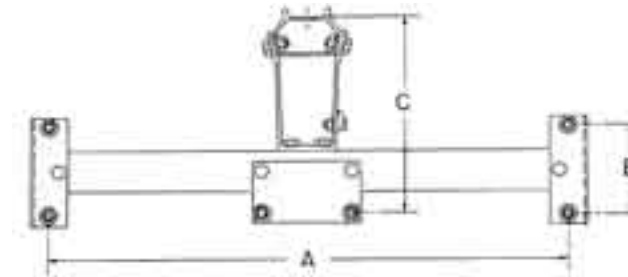

Models #WT3CA-48

For mounting cutouts, arresters or potheads. Mounts up to six pieces of equipment. Mounts with two 5/8" thru bolts (not supplied) Comes complete with equipment mounting hardware.

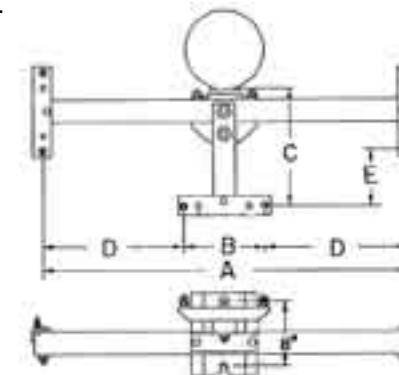

Models #W3CA-57-OS

For off-set mounting of cutouts, arresters, or potheads. Mounts up to 6 pieces of equipment. Mounts with two 5/8" thru bolts (not supplied). Comes complete with equipment mounting hardware.

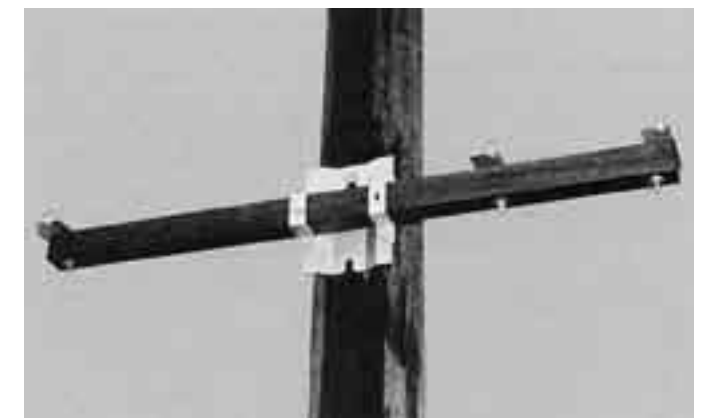
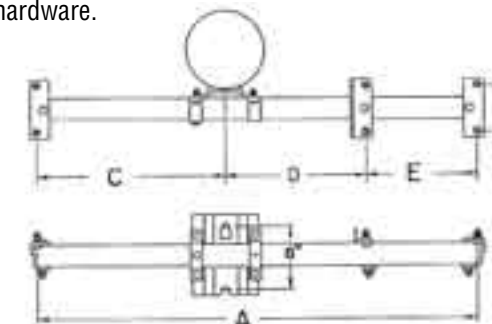

We make apitong equipment mounts up to 10 ft. Contact your Aluma-Form/Dixie representative for more information.

Catalog No.	Product No.	A	B	C	D	E
W3CA-35	51082	35"	6"	12 13/16"	-	-
W3CA-48	51153	48"	10"	12 13/16"	-	-
WT3CA-48	52032	46 3/8"	10"	14 1 1/16"	18 3/16"	7"
W3CA-57-OS	51120	55"	6"	27 1/2"	14"	13 1/2"

CAPACITOR RACKS ALUMA-FORM

For mounting 1 to 6 capacitors in line or up to 12 in a cluster, up to 200 KVAR

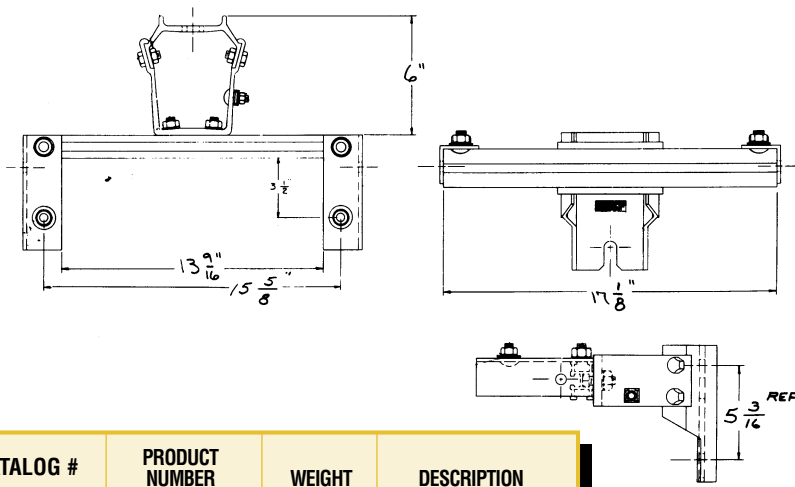

CATALOG #	PRODUCT NUMBER	WEIGHT	DESCRIPTION
CR-1	51513	4.5 lbs.	For mounting one capacitor

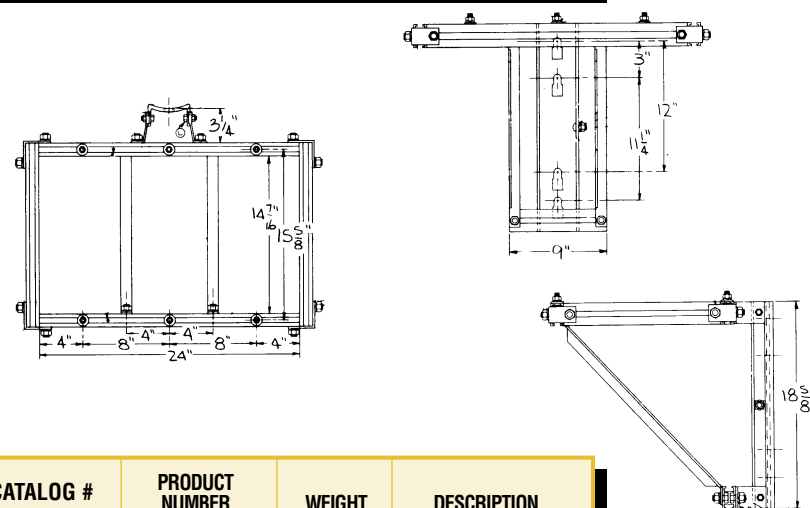

CATALOG #	PRODUCT NUMBER	WEIGHT	DESCRIPTION
CR-3	51509	17 lbs.	For mounting up to 3 capacitors

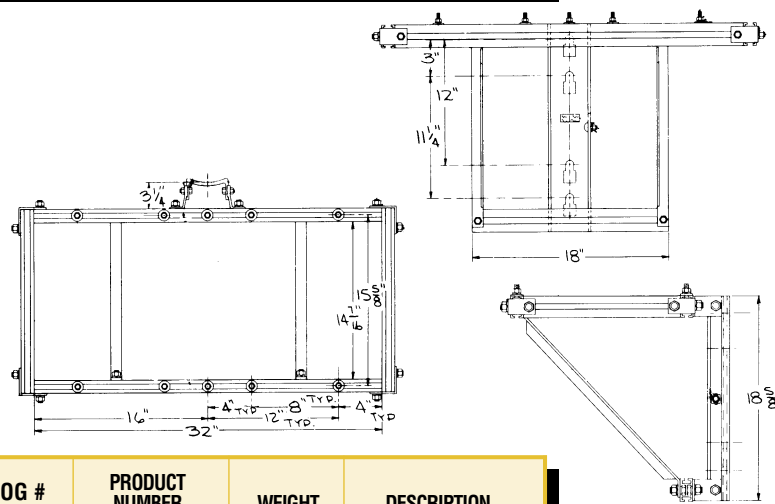

CATALOG #	PRODUCT NUMBER	WEIGHT	DESCRIPTION
CR-3/4	51510	18 lbs.	For mounting up to 4 capacitors

ALUMA-FORM CAPACITOR RACKS

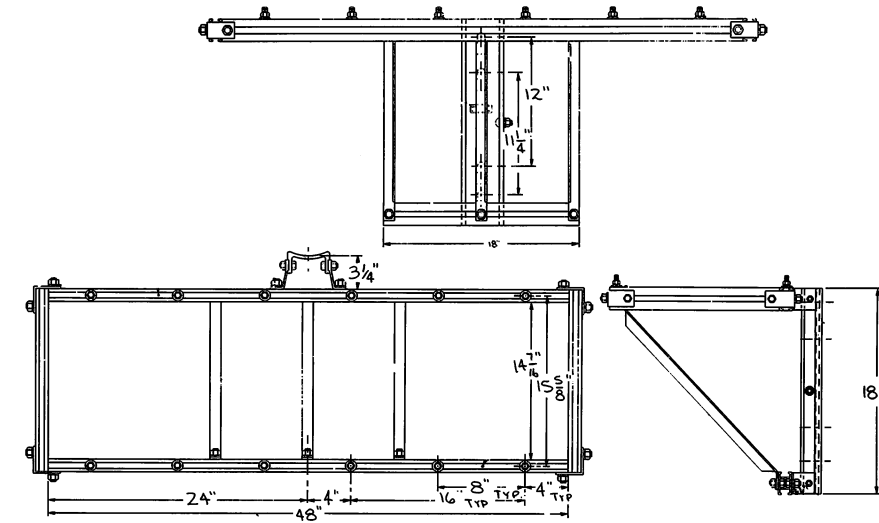

CATALOG #	PRODUCT NUMBER	WEIGHT	DESCRIPTION
CR-6	51512	22.5 lbs.	For mounting up to 6 capacitors

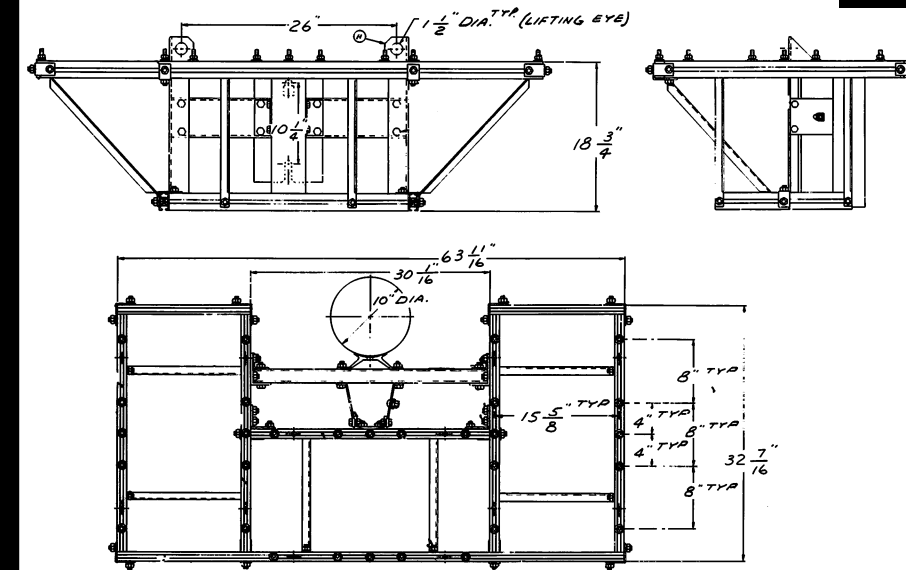

CATALOG #	PRODUCT NUMBER	WEIGHT	DESCRIPTION
CR-9/12	51523	85 lbs.	For mounting up to 12 capacitors

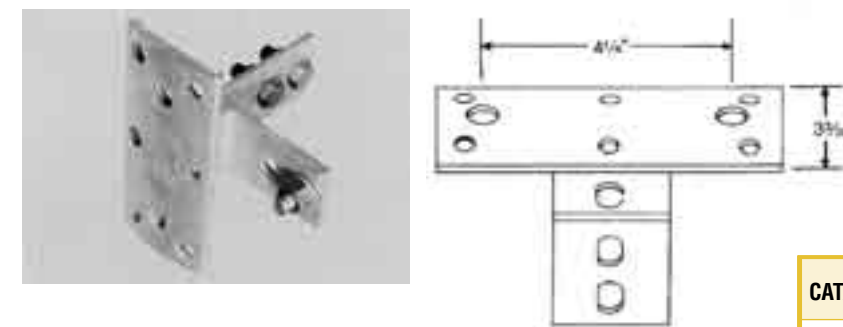

CATALOG #	PRODUCT NUMBER	WEIGHT	DESCRIPTION
OSM	51892	1.5 lbs.	Oil Switch Mount