

# CLUSTER MOUNT CATALOG

ALUMA-FORM, INC.

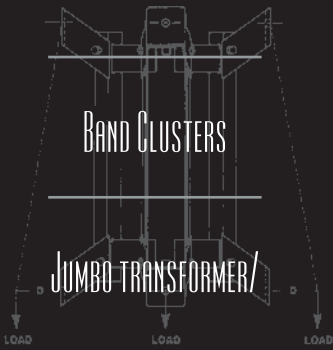

POLE RANGE DATA

SINGLE AND DUAL

POSITION THRU-BOLT

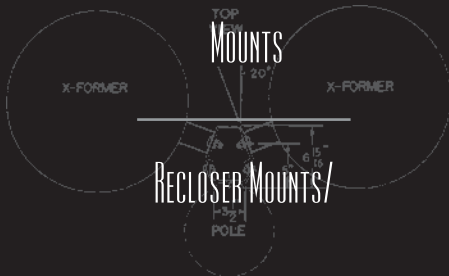

WING CLUSTERS



ALUMA-FORM®



## Index

|  |     |
|--|-----|
| Cluster Mount Features & Installation..... | 1   |
| Banded Cluster Mounts.....                 | 2   |
| Band-Type Loading Guide.....               | 3   |
| Accessories.....                           | 4   |
| Thru-bolt Mounts.....                      | 5   |
| Recloser Mounts.....                       | 6   |
| Wing Cluster Mounts.....                   | 7-8 |
| Wing-Type Loading Information.....         | 9   |

## Aluma-Form Band-Type Cluster Mounts

Combining the Best Features of Conventional Band and Wing Type Clusters without the disadvantages of either.

### Fast

Lineman can install transformer-ready in 5 minutes. Neatly boxed unit is completely preassembled at factory.

### Strong

Super-strong and corrosion-resistant 6061-T6 aluminum alloy extruded for high strength. No stronger cluster available.

### Safe

Light-weight boxed units are easy and safe to store. Only one man needed to install on the pole.



### Aluma-Form Cluster Mounts go up quick and easy.

1. Remove preassembled cluster from box. Instruction sheet and transformer mounting hardware are included.
2. Measure pole at desired height with tape provided. Cluster easily adjusts to wide range of pole sizes.
3. For one-man installation, hang cluster on lag screw. (Lag screw locates cluster & DOES NOT BEAR LOAD).
4. Tighten double arming bolts as tight as possible. Cluster now ready to receive transformers.

# BANDED CLUSTER MOUNTS **ALUMA-FORM**<sup>®</sup>

## Available in a wide range of models

All models are available in three pole size ranges and packaged in sturdy boxes; sufficient hot dipped galvanized transformer mounting bolts, nuts and lockwashers furnished; ground wire clamp, instruction sheet, and pole measuring tape furnished. See price sheet for further ordering information.

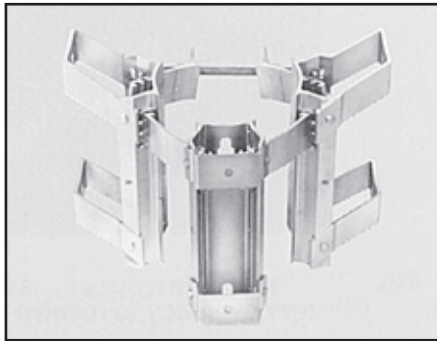

### Model 6M3-6M

Mounts three 3kVA thru 50kVA transformers with 12" ANSI/NEMA type A lugs. Complete with 5/8" transformer mounting hardware and ground clamp.

Provides extra pole bearing surface giving increased support on extremely soft or old poles. Maintains vertical position of transformers where appearance is a factor.



### Jumbo Band Clusters Model 15M3-9-14-36

Triple band cluster mounts three 3kVA thru 500kVA transformers with ANSI/NEMA type A, B, or C, lugs

having 12", 24" or 36" lug spacing. Includes EP-18 extension plates and large pole band for use on 9.5" to 19" diameter poles. Included transformer mounting hardware & ground clamp. Required for use with 333kVA & 500kVA transformers or regulators which have 36" lug spacing. NEMA C adapter plates not supplied.

**Double Band Cluster Mounts** 3kVA thru 167kVA transformers, any combination of 12" or 24" ANSI/NEMA Type A and B lugs. If adapters are used 167kVA thru 250kVA transformers with ANSI/NEMA Type C lugs can be mounted.

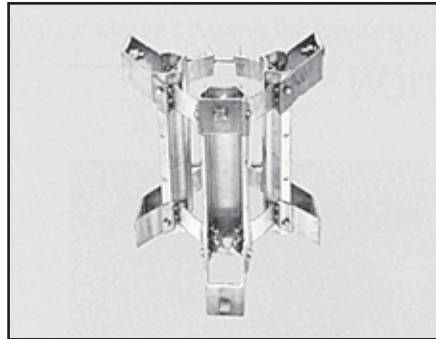

### Mounts Three Transformers

| Model     | Distance from pole |
|-----------|--------------------|
| #15M3-6   | 6"                 |
| #15M3-9   | 9"                 |
| #15M3-969 | 9"-6"-9"           |

**Single Band Cluster Mounts** 3kVA thru 50kVA transformers (latest standards) with 12" ANSI/NEMA type A lugs.

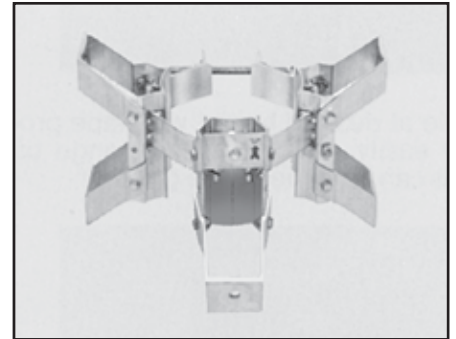

### Mounts Three Transformers

| Model    | Distance from pole |
|----------|--------------------|
| #6M3-6   | 6"                 |
| #6M3-9   | 9"                 |
| #6M3-969 | 9"-6"-9"           |

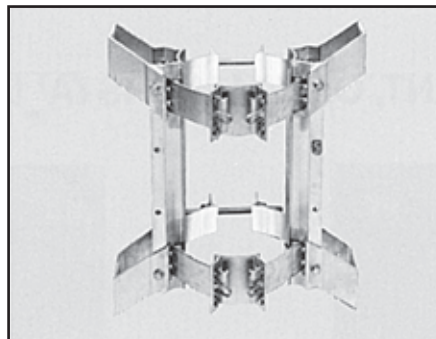

### Mounts Two Transformers

| Model  | Distance from pole |
|--------|--------------------|
| 10M2-6 | 6"                 |
| 10M2-9 | 9"                 |



### Mounts two Transformers

| Model  | Distance from pole |
|--------|--------------------|
| #4M2-6 | 6"                 |
| #4M2-9 | 9"                 |

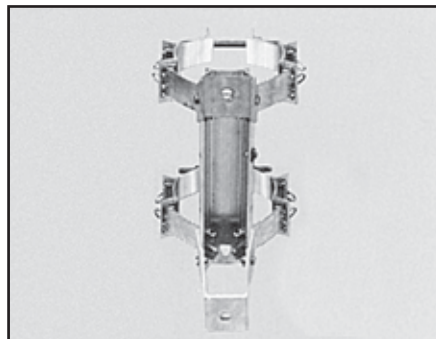

### Mounts One Transformers

| Model  | Distance from pole |
|--------|--------------------|
| #5M1-6 | 6"                 |
| #5M1-9 | 9"                 |

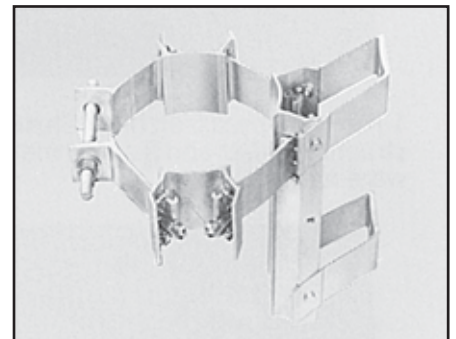

### Mounts One Transformers

| Model   | Distance from pole |
|---------|--------------------|
| #2M1-6M | 6"                 |
| #2M1-9M | 9"                 |



# ALUMA-FORM® BANDED CLUSTERS LOADING GUIDE

ALUMA-FORM® a leader in the development and manufacture of aluminum alloy cluster mounting brackets, and with many years of research and experience, publishes our loading recommendations in an effort to assist users toward prudent product selection.

Normally our small cluster mounts (3–50kVA) are mechanically evaluated with per phase load applied at a 14" moment from their mounting pad surface. Our larger cluster mounts (50–500kVA) are mechanically evaluated with per phase load applied at least at an 18" moment from their mounting pad surface.

In actual practice, the center of gravity of electrical equipment frequently exceeds 14" or 18" from their mounting lugs. This increased distance is a moment arm and effectively "multiplies" the load carried by the cluster mount.

Since the main factors acting internally are combined bending, compression, tension and shear, a simple formula of ratio of moment arm lengths is not sufficient for determining recommended loading.

ALUMA-FORM®, therefore, provides the following Recommended Maximum Load per Phase data based upon empirical evaluations and engineering analyses for our various popular models of cluster mounting brackets. These loads are conservative and typically include a least a 2:1 safety factor. The customer is cautioned, however, that the accompanying data is published only for general information in assisting in cluster mount selection. The customer is advised to check pole loading, both in column strength and in butt bearing load. This data is subject to change without notice.

## BAND-TYPE CLUSTER MOUNTS

| Model        | Maximum Recommended Equipment Load (in pounds), <i>per position</i> , for distance (in inches) from mounting pad face to equipment center of mass (C.O.G.): |            |            |            |
|--------------|---|------------|------------|------------|
|              | 14"   | 18"        | 22"        | 26"        |
| 4M2-6        | 1,275 lbs.  | 1,000 lbs. | 820 lbs.   | 690 lbs.   |
| 5M1-6        | 3,200 lbs.  | 2,500 lbs. | 2,000 lbs. | 1,725 lbs. |
| 5M1-9        | 2,500 lbs.  | 1,950 lbs. | 1,600 lbs. | 1,350 lbs. |
| 6M3-6        | 1,275 lbs.  | 1,000 lbs. | 820 lbs.   | 690 lbs.   |
| 6M3-6-5      | 1,275 lbs.  | 1,000 lbs. | 820 lbs.   | 690 lbs.   |
| 6M3-6-M      | 2,140 lbs.  | 1,650 lbs. | 1,375 lbs. | 1,150 lbs. |
| 10M2-6       | 3,200 lbs.  | 2,500 lbs. | 2,000 lbs. | 1,725 lbs. |
| 10M2-9       | 2,500 lbs.  | 1,950 lbs. | 1,600 lbs. | 1,350 lbs. |
| 15M3-6       | 3,200 lbs.  | 2,500 lbs. | 2,000 lbs. | 1,725 lbs. |
| 15M3-6-5     | 3,200 lbs.  | 2,500 lbs. | 2,000 lbs. | 1,725 lbs. |
| 15M3-9       | 2,500 lbs.  | 1,950 lbs. | 1,600 lbs. | 1,350 lbs. |
| 15M3-9-5     | 2,500 lbs.  | 1,950 lbs. | 1,600 lbs. | 1,350 lbs. |
| 15M3-969     | 2,500 lbs.  | 1,950 lbs. | 1,600 lbs. | 1,350 lbs. |
| 15M3-6-14-36 | 5,000 lbs.  | 3,900 lbs. | 3,200 lbs. | 2,700 lbs. |
| 15M3-9-14-36 | 4,000 lbs.  | 3,100 lbs. | 2,550 lbs. | 2,100 lbs. |
| 6M3-9        | 1,020 lbs.  | 800 lbs.   | 660 lbs.   | 550 lbs.   |
| 6M3-969      | 1,020 lbs.  | 800 lbs.   | 660 lbs.   | 550 lbs.   |
| 4M2-9        | 1,020 lbs.  | 800 lbs.   | 660 lbs.   | 550 lbs.   |
| 2M1-6M       | 2,140 lbs.  | 1,650 lbs. | 1,375 lbs. | 1,150 lbs. |
| 2M1-9M       | 1,020 lbs.  | 800 lbs.   | 660 lbs.   | 550 lbs.   |

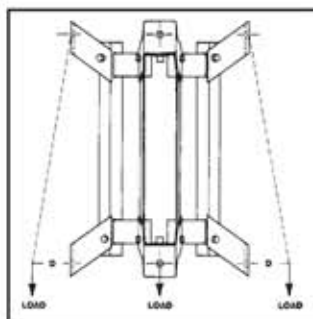

**BAND-TYPE**

# BANDED CLUSTER MOUNT ACCESSORIES **ALUMA-FORM®**

## Model 321-A Adapter Plate

For mounting 167kVA and larger transformers with ANSI/NEMA type C lugs (2 plates required per transformer). Unique slot feature captures 2/4" mounting bolt head, allows one hand tightening of bolt, and provides completely jump proof feature. Two 5/8" x 2" (ANSI C135.1) hot-dipped galvanized machine bolts with nut and lockwasher are included with each plate. Balance of mounting bolts required are included with cluster mount.

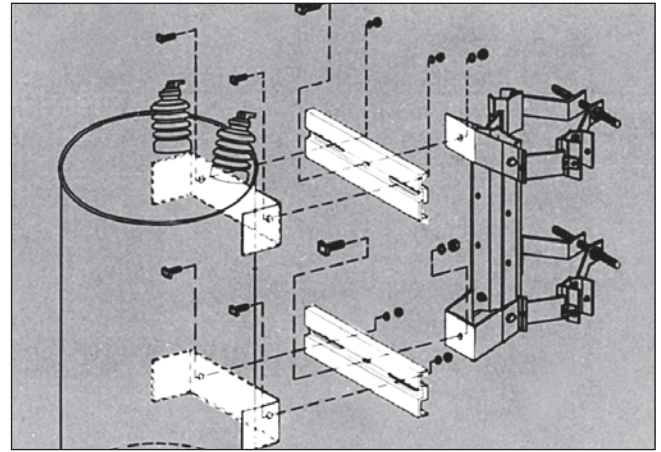
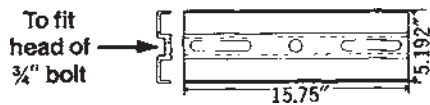

Transformer with type C lug

321A Adapter

Cluster Mount

## Model EP-18 Extension Plate

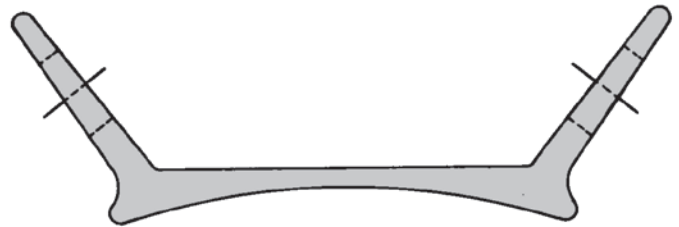
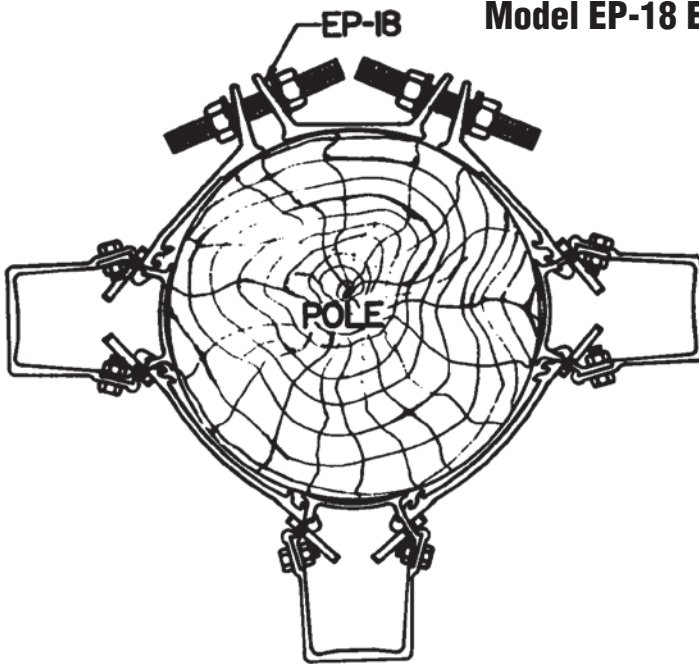

One EP-18 extension plate required for each band.

**Example:**

6M3-6 (single band) use one EP-18  
15M3-6 (double band) use two EP-18's

EP-18 Extension Plates can be used with any Aluma-Form band type cluster to increase pole range. (see chart below) Extra bolts, nuts, and washers are provided.

## Pole Ranges

Aluma-Form band type clusters can be mounted on poles 6-1/2" to 19" in diameter.

| TYPE     | POLE DIA. RANGE | CAT. NUMBER                  | EXAMPLE               | EP-18 WILL INCREASE MAX. DIA. TO |
|----------|-----------------|------------------------------|-----------------------|----------------------------------|
| Small    | 6-1/2"–11-1/2"  | ADD-5 to Standard Model No.  | 6M3-6-5<br>15M3-6-5   | 16-1/2"                          |
| Standard | 7-3/4"–12-1/4"  | Standard Models              | 6M3-6<br>15M3-6       | 17-1/2"                          |
| Large    | 9-1/2"–14"      | ADD-14 to Standard Model No. | 6M3-6-14<br>15M3-6-14 | 19"                              |

## THRU-BOLT SINGLE POSITION MOUNTS

### Model TB2M1-6

For mounting one 3kVA thru 50kVA transformer, recloser or sectionalizer, having 12" ANSI/NEMA type A lugs (no adapter plate required). Ground wire clamp and 5/8" hot-dipped galvanized transformer mounting hardware furnished with mount. Attaches to pole with two 5/8" diameter thru-bolts (not supplied) at 7-1/16" hole spacing. Mounts equipment 6" from pole surface.

### Model TB2M1-9

Same as above except mounts equipment 9" from pole surface.

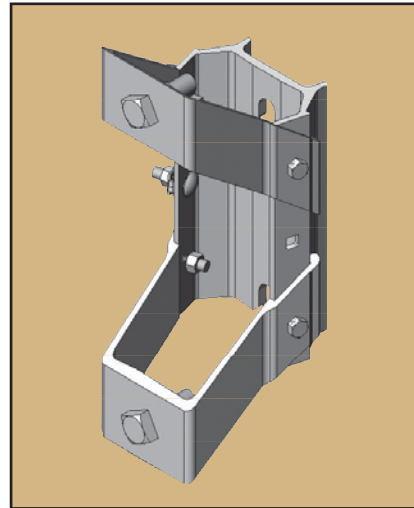

### Model TB5M1-6

For mounting one 3kVA thru 100kVA transformer, having 12" or 24" ANSI/NEMA type A or B lugs. If type C adapter plates are used a 167kVA thru 333kVA transformers can be mounted. Ground wire clamp and a 3/4" hot-dipped galvanized transformer mounting hardware furnished with mount. Attaches to pole with two (or three) 3/4" diameter thru-bolts (not supplied) at 17-1/2" hole spacing. Mounts equipment 6" from pole surface.

### Model TB5M1-9

Same as above except mounts equipment 9" from the pole surface.

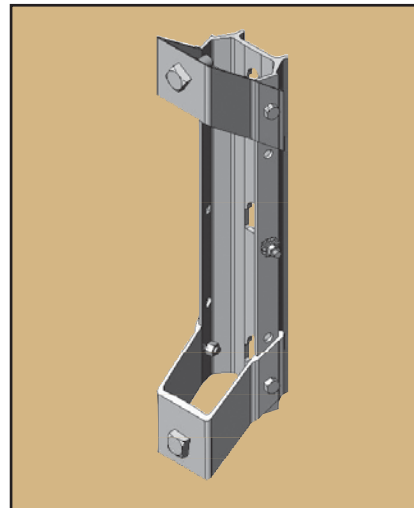

## THRU-BOLT DUAL POSITION MOUNTS

### Model DM-2M2

Mounts two 3kVA thru 50kVA transformers with 12" ANSI/NEMA type A lugs. Complete with 5/8" hot-dipped galvanized transformer mounting hardware and ground clamp. Attaches to pole with two 5/8" diameter thru-bolts (not supplied) at 12" hole spacing. Mounts equipment as illustrated.

### Model DM-4M2

Mounts two 3kVA thru 100kVA transformers with 12" or 24" ANSI/NEMA type A or B lugs. Complete with four 3/4" and two 5/8" hot-dipped galvanized transformer mounting hardware, and ground clamp. Attaches to pole with two 3/4" diameter thru-bolts (not supplied) at 25-3/4" hole spacing. Mounts equipment as illustrated.

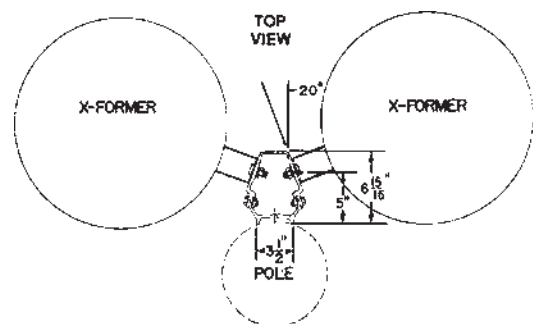
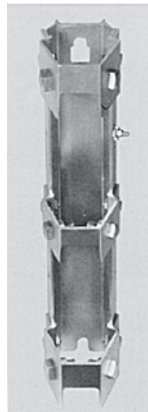
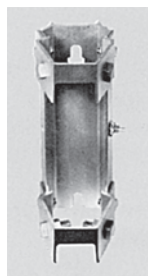

Typical Installation



# RECLOSER MOUNTS **ALUMA-FORM**<sup>®</sup>

## MOUNTS FOR OIL CIRCUIT RECLOSERS & SECTIONALIZERS

### Banded Models

These models include all the features of Aluma-Form banded cluster mounts. Extended segments are 9" from pole surface for clearance of live parts and easy working access to linemen. Each unit complete with recloser mounting bolt, nut, and lockwasher per position. Punched holes are provided in sides of extended segments for mounting arresters. Shipped completely assembled in sturdy carton.

*Note:* tighten double arming bolt as tight as possible.

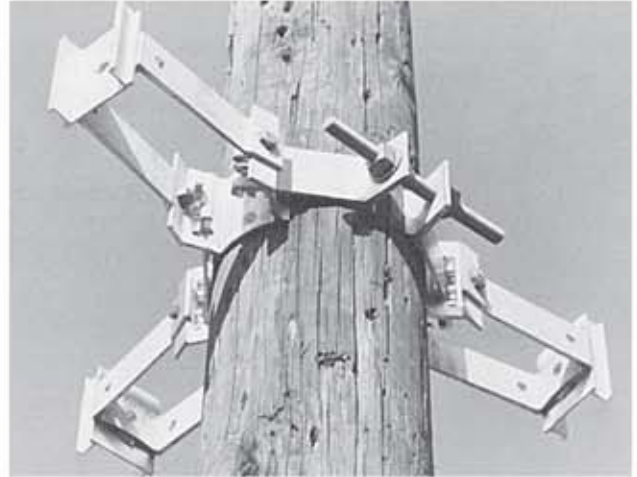

Model RSM01 for mounting one unit



Model RSM-2 for mounting two units



Model RSM-3 for mounting three units

## Thru-Bolt Models for 3-Phase Applications

### 3SPR-66

Single position mount with same features as banded models above except attaches to pole with one 5/8" diameter thru-bolt and one 1/2" lag screw (not supplied) at 3-5/8" hole spacing.

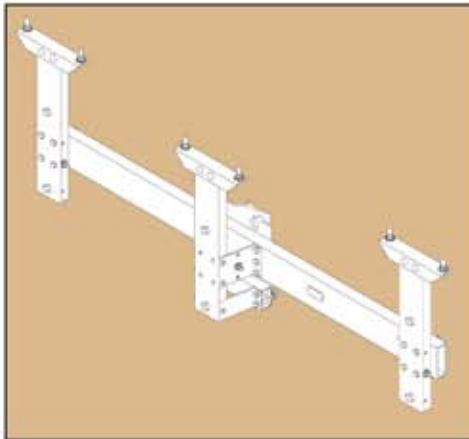



# ALUMA-FORM® WING CLUSTERS

**A complete line of compact, light-weight wing-type cluster mounts for mounting up to three 250kVA transformers. Unique design eliminates welding. Rigid, pre-assembled mounts are constructed of interlocking 6061-T6 aluminum extrusions and offer the utility a broad range of outstanding features.**

### No welds

Unique design eliminates welding. Interengaged extrusions allow utilization of the full strength of the metal which otherwise has to be derated in the area of any weld in accordance with recommended design parameters of A.S.C.E. Only Aluma-Form clusters are made without welding.

### Rigid one-piece construction

Rigid pre-assembled mounts are easy to handle, provide excellent climbing space, look better when installed, and stay that way.

### Strong, compact light-weight

Interengaged 6061-T6 aluminum alloy extrusions provide the strongest and lightest weight assemblies possible. Easy to handle and maintenance free.

### Can be assembled on ground

If desired units may be prewired on ground and hoisted into position on pole.

### Pre-assembled

One piece assemblies are ready to install as received without any adapter plates for ANSI/NEMA "A" or "B" lugs. 167kVA & larger transformers having dual bolt ANSI/NEMA "C" lugs can be mounted with any standard ANSI/NEMA type C adapter.

| Thru Bolt Mounts<br>(thru-bolts not supplied) | Model #                              | Description  | Weight   |
|---|--------------------------------------|--|----------|
|   | 3MW-24-M                             | Mounts three 3kVA through 50kVA transformers with 12" ANSI/NEMA type "A" lugs. No adapter plates required.   | 20.3 lbs |
|   | 3MW-24-M-L                           | Same as above, except it includes lifting eye hardware for hoisting assembly.  | 22.5 lbs |
|   | 3MW-24                               | Mounts three 3kVA through 50kVA transformers with 12" ANSI/NEMA type "A" lugs. No adapter plates required.   | 20.2 lbs |
|   | 11MW-24                              | Mount three 3kVA through 167kVA units to both ANSI/NEMA 12" or 24", type A or B lugs.  | 34 lbs   |
|   | 11 MW-24-L                           | Same as above, except includes lifting eye hardware for hoisting assembly.   | 35.5 lbs |
|   | 12MW-24                              | Mounts three 3kVA through 100kVA transformers and combination of 12" or 24" ANSI/NEMA type "A" or "B" lugs. If 321-B adapter plates are used, 167 and 250kVA transformers can be mounted.                  | 34 lbs   |
|   | 12MW-30                              | Mounts three 3kVA through 100kVA transformers and combination of 12" or 24" ANSI/NEMA type "A" or "B" lugs. If 321-B adapter plates are used, 167kVA transformers can be mounted.                          | 36 lbs   |
| Transformer Mounting Hardware                 | Suffix Letters<br>A<br>(ANSI C135.1) | Six 5/8" x 2" hot galv. sq. hd. bolts, hex nuts and lockwashers are required for type A lugs.  | 2 lbs    |
|   | B<br>(ANSI C135.1)                   | Six 3/4" x 2" hot galv. sq. hd. bolts, hex nuts and lockwashers are required for type B lugs.  | 3 lbs    |
|   | C                                    | Six 5/8" x 2-1/2" high strength ASTM A325 hot galv. sq. hd. bolts, hex nuts and lockwashers. For use with all transformer lugs. 3/4" head, 5/8" thread.  | 2.5 lbs  |
|   | AB                                   | A combination of "A" & "B" above for both "A" & "B" lugs.  | 5 lbs    |
| ANSI/NEMA C MTG. lug adapters (167 & 250kVA)  | 321-B                                | Aluminum adapter plate with one 3/4" x 2-3/4" ANSI C135.1 galv. bolt for attaching adapter to cluster (two required per transformer) note: ANSI/NEMA "C" transformer lugs require two model A bolts packs. | 3 lbs    |

# WING CLUSTER MOUNTS **ALUMA-FORM®**

## **Model 3MW-24-M**

Mounts 3 through 50kVA transformers, up to 1,000 pounds per phase at an 18" moment. Mounts to the pole on 13" hole centers using two 3/4" through-bolts (not supplied). Furnished with 5/8" transformer mounting hardware.

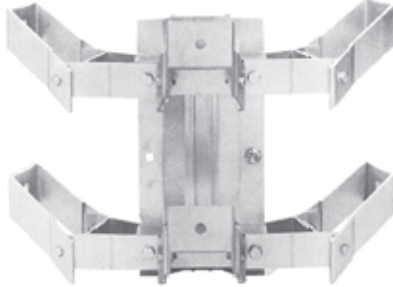

## **Model 3 MW-24**

For mounting up to three 50kVA transformers with 12" ANSI/NEMA type A lugs. Pole thru-bolt holes are 3/4" on 12" centers (thru-bolts not supplied).

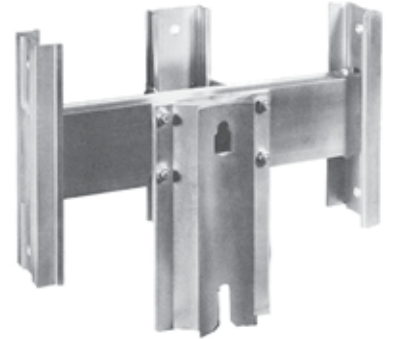

## **Model 11 MW-24**

Mounts 3 through 167kVA transformers, up to 2,000 pounds per phase at an 18" moment. Mounts to the pole on 18" or 12" hole centers using two or three 3/4" through-bolts (not supplied). Furnished with our unique, high strength transformer mounting bolts and hardware.

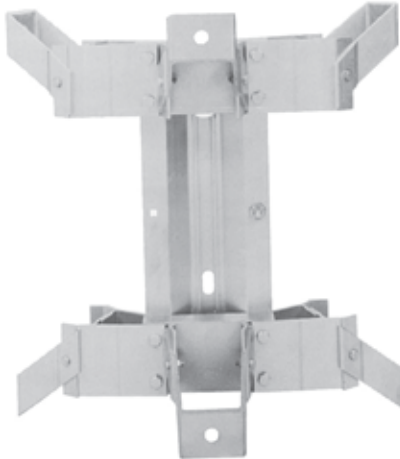

## **Model 12 MW-24**

Model 12 MW-24 allows 24" of spacing between outside positions. For mounting up to three 250kVA transformers. Pole thru-bolt holes are 3/4" on 15" centers (thru-bolts not supplied).



## **Model 12 MW-30**

Model 12 MW-30 allows 30" of spacing between outside positions. For mounting up to three 167kVA transformers. Pole thru-bolt holes are 3/4" on 15" centers (thru-bolts not supplied).



Although there are no industry standards for cluster mounts, Aluma-Form®, as a leader in the development and manufacture of clusters, and with many years of research and experience having been logged, feels it necessary to publish our recommendations in an effort to assist users toward prudent product selection.

Normally cluster mounts are load tested with loads applied eighteen (18) inches from the transformer mounting surface of the cluster.

In actual practice, the center of gravity of large transformers may be more than eighteen (18) inches from the face of the cluster. Some designs are found to have the load center as much as twenty-six (26) inches from the cluster face. This increased distance acts as a moment arm and “multiplies” the load carried by the cluster mount.

Since the main factors acting internally are combined bending, compression, tension, and shear, a simple formula based on moment arms is not totally satisfactory for determining recommended loadings.

Aluma-Form®, therefore, feels that the distance of the center of gravity from the cluster should be taken into account along with the weight of the transformer when applying very heavy loads. The list below contains Aluma-Form’s recommended loading data for various cluster mounts. The customer is cautioned however that the accompanying data is published only for general information in assisting in cluster mount selection. The customer is advised to check pole loading, both in column strength and butt bearing load.

## WING-TYPE CLUSTER MOUNTS

| Model    | Maximum Recommended Equipment Load (in pounds), <i>per Cluster Mount Phase</i> , for typical distance (in inches) from mounting pad face to equipment center of mass (C.O.G.): |            |            |            |
|----------|--|------------|------------|------------|
|          | 14”  | 18”        | 22”        | 26”        |
| 3MW-24   | 625 lbs.   | 500 lbs.   | 410 lbs.   | 350 lbs.   |
| 3MW-24-M | 1,250 lbs.   | 1,000 lbs. | 820 lbs.   | 700 lbs.   |
| 11MW-24  | 2,500 lbs.   | 2,000 lbs. | 1,640 lbs. | 1,385 lbs. |
| 12MW-24  | 2,500 lbs.   | 1,950 lbs. | 1,600 lbs. | 1,350 lbs. |
| 12MW-30  | 2,000 lbs.   | 1,550 lbs. | 1,275 lbs. | 1,075 lbs. |

