



Single-phase overhead
distribution switches
Types DCD, RBD, SID, LSID, and ITD

DCD distribution class disconnect switch

Product features

- Base and back strap: strengthened channel of galvanized steel for corrosion protection and solid operation
- Insulators available in silicone or porcelain
- Self-aligning silver to silver contacts ensure long life
- Entire blade is copper plated
- Loadbreak hooks made of galvanized steel for corrosion protection, to be used with loadbreak tool
- Standard two-hole NEMA plated pad or optional two-piece parallel groove
- All testing is in accordance with IEEE 37.34

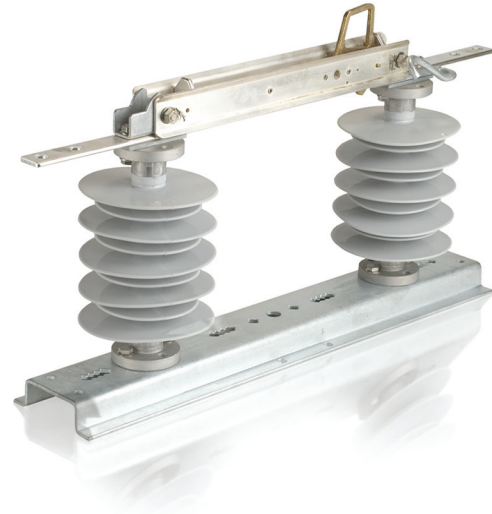

Application

The DCD disconnect switch is a hookstick-operated switch used to sectionalize or isolate circuits on electrical distribution systems through 38 kV. The distribution switch can be mounted on a single or double crossarm and is rated for 600 or 900 A continuous current and 65 kA peak withstand current (40 kA momentary).

Operation

ABB disconnect switches include loadbreak hooks for use with a portable loadbreak tool. Silver-plated contacts enhance efficient current transfers. The pull-ring activates the latch as a pry-out lever for easy opening and ice breaking.

Blade operation

A blade stop limits the blade range of motion to the 90° and 160° positions, and a latch prevents the switch from opening under high momentary current.

Mounting

The DCD can be mounted in the following configurations:

- Vertical or underhung
- Polemount
- Single or double crossarm

Outline drawing

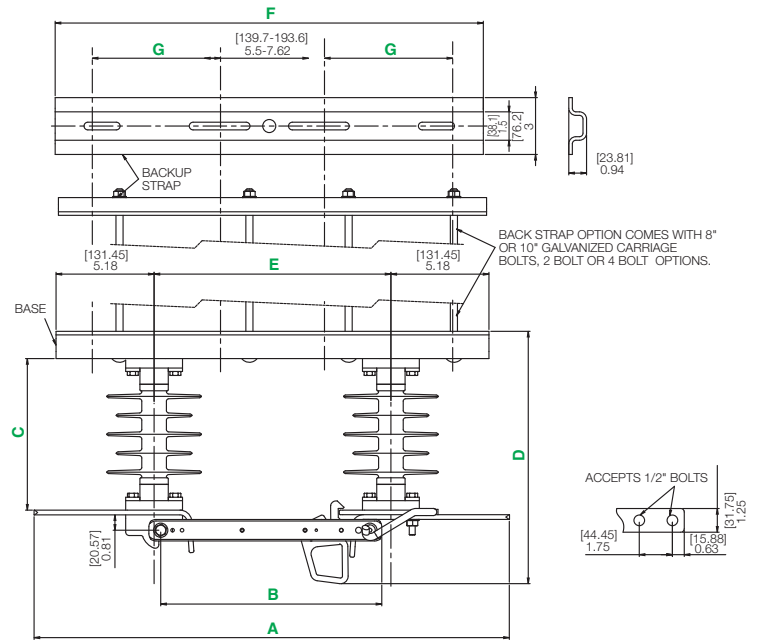

Unit dimensions

Voltage class (kV)	BIL (kV)	A		B		C		D		E		F		G		Porcelain weight (lb) (kg)		Silicone weight (lb) (kg)	
		(in)	(mm)	(in)	(mm)	(in)	(mm)	(in)	(mm)	(in)	(mm)	(in)	(mm)	(in)	(mm)	(lb)	(kg)	(lb)	(kg)
15	110	25.10	637	11.67	296	8.00	203	13.29	338	12.50	317	22.60	574	4.63-6.77	118-172	40 (600 A)	18	21 (900 A)	9.5
27	125	28.57	726	15.07	383	9.00	229	14.29	363	15.90	404	26.00	660	6.38-8.47	162-215	42 (600 A)	19	23 (600 A)	10
38	150	28.57	726	15.07	383	10.0	254	15.32	389	15.90	404	26.00	660	6.38-8.47	162-215	44 (600 A)	20	26 (900 A)	12

Insulator details

Voltage class (kV)	BIL (kV)	Creep				Strike			
		Porcelain		Silicone		Porcelain		Silicone	
		(in)	(mm)	(in)	(mm)	(in)	(mm)	(in)	(mm)
15	110	17.60	441	19.53	496	7.71	196	7.79	198
27	125	22.95	583	28.30	719	8.55	217	9.26	234
38	150	23.87	606	39.52	1003	9.81	249	10.62	270

Ratings

Maximum voltage (kV)	BIL (kV)	Continuous current (A)	Peak withstand current (kA Asym)
15	110	600/900	65
27	125	600/900	65
38	150	600/900	65

Selection guide

Description	Code	Definition
Switch type	S	Type DCD switch
	1	15 kV, 110 kV BIL
	2	27 kV, 125 kV BIL
Max kV, BIL	5	38 kV, 150 kV BIL
	N	No stop
	A	90° stop
Blade stop	B	160° stop
	P	Porcelain – gray 2.25" bolt circle
Insulators	J	Silicone – gray 2.25" bolt circle
	A	NEMA 2-hole with captured 0.5" hardware (galvanized)
Terminal connectors	C	NEMA 2-hole with two-piece clamshell #2-500MCM (10013A44G01)
	N	NEMA 2-hole pad – standard
	H	NEMA 2-hole with two-piece clamshell 4/0-500MCM (10013A44G02)
Base	S	Smooth slots in base for 0.5" carriage bolts
	C	Serrated slots in base for .375" carriage bolts
	N	No back bracket
Mounting brackets	8	Two 8" long, .375-16 carriage bolts with back bracket and hardware
	1	Two 10" long, .375-16 carriage bolts with back bracket and hardware
	A	Four 8" long, .375-16 carriage bolts with back bracket and hardware
	B	Four 10" long, .375-16 carriage bolts with back bracket and hardware
Unused	N	Space holder for future options
Continuous current	6	600 amperes
	9	900 amperes
Specials	0	None
	B	Stainless steel nameplate

Example: S2BJNC1N60 = DCD, 27 kV, 125 kV BIL, 160° stop, silicone insulators, standard NEMA 2-hole pads, base with serrated slots, back bracket with two 10" carriage bolts and hardware, 600 A, no specials

DCD mounting configurations

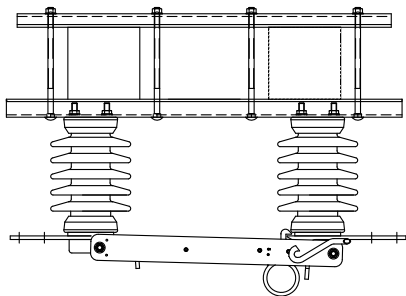

Vertical or underhung

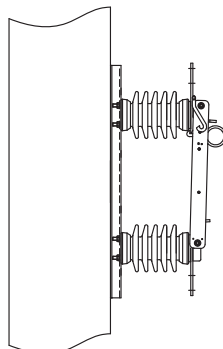

Polemount

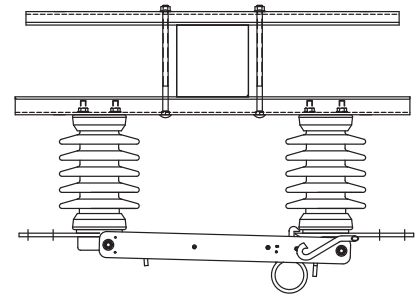

Single crossarm

RBD distribution class bypass disconnect switch

Product features

- Base and back strap: strengthened channel of galvanized steel for corrosion protection and solid operation
- Insulators available in silicone or porcelain
- Self-aligning silver to silver contacts ensure long life
- Entire blade is copper plated
- Loadbreak hooks made of galvanized steel for corrosion protection, to be used with loadbreak tool
- Bypass blade is left- or right-hand operation
- Standard two-hole NEMA plated pad or optional two-piece parallel groove
- All testing is in accordance with IEEE 37.34



Application

The RBD distribution bypass disconnect switch provides an economical means for bypassing and disconnecting reclosers or other equipment, allowing quick system reconfigurations to perform maintenance on any device without interrupting service.

Operation

In normal operation, the bypass blade is open and the two disconnect blades are closed, allowing the unit to be energized. When maintenance, testing, repair, or removal is required, first close the bypass blade to provide a parallel current path. Then open both disconnect blades of the bypass switch. Service continuity is maintained and the unit is isolated from the line. Reverse the process to put the unit back in service.

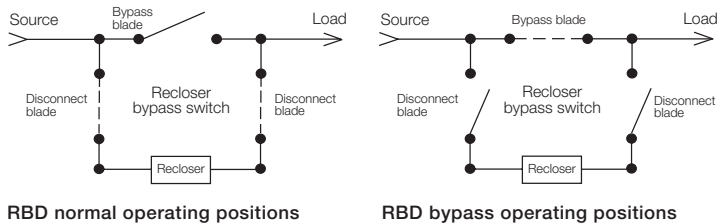

RBD normal operating positions

RBD bypass operating positions

Blade operation

A blade stop limits the blade range of motion to the 90° and 160° positions, and a latch prevents the switch from opening under high momentary current.

Mounting

The RBD can be mounted in the following configurations:

- Vertical or underhung
- Polemount
- Single or double crossarm

RBD mounting configurations

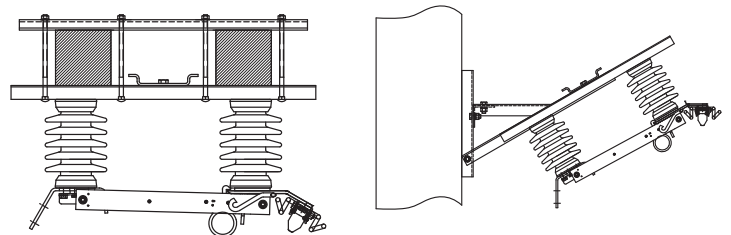

Outline drawing

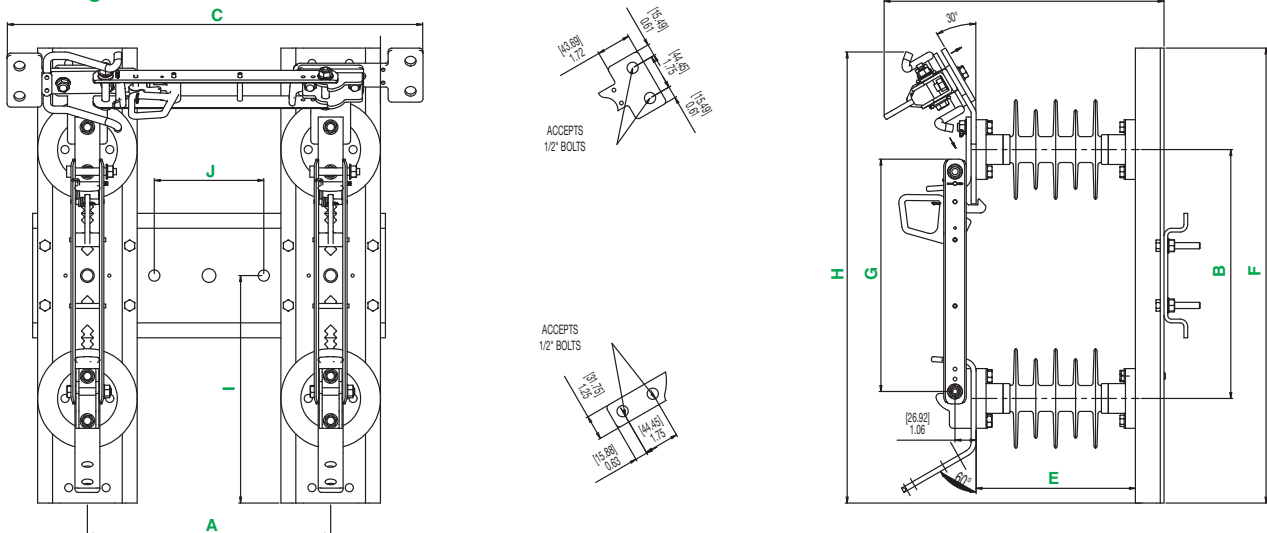

Insulator details

Voltage class (kV)	BIL (kV)	Creep				Strike			
		Porcelain		Silicone		Porcelain		Silicone	
(in)	(mm)	(in)	(mm)	(in)	(mm)	(in)	(mm)	(in)	(mm)
15	110	17.60	441	19.53	496	7.71	196	7.79	198
27	125	22.95	583	28.30	719	8.55	217	9.26	234
38	150	23.87	606	39.52	1003	9.81	249	10.62	270

Ratings

Maximum voltage (kV)	BIL (kV)	Continuous current (A)	Peak withstand current (kA Asym)
15	110	600/900	65
27	125	600/900	65
38	150	600/900	65

Selection guide

Description	Code	Definition
Switch type	R	Type RBD bypass switch
	1	15 kV, 110 kV BIL
	2	27 kV, 125 kV BIL
Max kV, BIL	5	38 kV, 150 kV BIL
	N	No stop
Blade stop for parallel disconnect blades	A	90° stop
	N	No stop (not available on crossarm mounting)
Blade stop for bypass disconnect blade	A	90° stop (required on crossarm mounting)
	B	160° stop (not available on crossarm mounting)
	P	Porcelain – gray 2.25" bolt circle
Insulators	J	Silicone – gray 2.25" bolt circle
	A	NEMA 2-hole with captured 0.5" hardware (galvanized)
Terminal connectors	C	NEMA 2-hole with two-piece clamshell #2-500MCM (10013A44G01)
	N	NEMA 2-hole pad – standard
	H	NEMA 2-hole with two-piece clamshell 4/0-500MCM (10013A44G02)
	N	No back bracket
Mounting brackets	8	Four 8" long, .375-16 carriage bolts with two back brackets and hardware
	1	Four 10" long, .375-16 carriage bolts with two back brackets and hardware
	P	Pole mount frame 30° from horizontal
	Y	Galvanized steel crossarm combo (3 RBDs on crossarm)
Bypass blade	Z	Non-metal crossarm combo (3 RBDs on crossarm)
	L	Left-hand operation of bypass blade (operates to the left)
Continuous current	R	Right-hand operation of bypass blade (operates to the right)
	6	600 amperes
Specials	9	900 amperes
	0	None

Example: R1NAPNPL60 = RBD, 15 kV, 110 kV BIL, no stops on parallel blades, 90° stop on bypass blade, porcelain insulators, 2-hole NEMA pads, polemount frame, left hand operation of bypass blade, 600 A, no specials

Unit dimensions

Voltage class (kV)	BIL (kV)	A		B		C		D		E		F		G		H		I		J		Porcelain weight (lb)	Silicone weight (kg)		
		(in)	(mm)	(in)	(mm)	(in)	(mm)	(in)	(mm)	(in)	(mm)	(in)	(mm)	(in)	(mm)	(in)	(mm)	(in)	(mm)	(in)	(mm)				
15	110	12.22	310	12.50	317	20.86	530	14.03	356	8.0	203	22.6	574	11.67	296	22.49	571	11.43	290	5.50	140	91	41	54	24
27	125	15.63	397	15.90	404	24.27	617	15.03	382	9.0	229	26.0	660	15.07	383	25.82	656	13.13	333	5.50	140	99	45	55	25
38	150	15.63	397	15.90	404	24.27	617	15.03	382	10.0	254	26.0	660	15.07	383	25.82	656	13.13	333	5.50	140	103	47	57	26

SID disconnect switch

Product features

- Offered in three voltage classes and four BIL sizes. Each voltage class is designed for 600 A or 900 A continuous load with 65 kA peak (40 kA momentary) rating.
- Silicone, polymer concrete, or porcelain insulators available
- Lightweight alternative to double insulator disconnect switch
- Use of single insulator reduces need of double crossarm for mounting when using cutout bracket
- Four mounting configurations available
- All testing is in accordance with IEEE 37.34

Description

The SID disconnect switch is a single insulator disconnect with a double-bar switch blade and two, 2-hole extended NEMA pad terminals. The SID is a lightweight, flexible alternative to the commonly used double insulator design. In addition, the SID disconnect incorporates the ABB quality approach to cutout design.

Application

The SID is used as a disconnect on overhead distribution feeders and in outdoor distribution substations. It is used to provide a visible break point for maintenance personnel, as a sectionalizing point, or as a loadbreak switch when used in conjunction with a portable loadbreak tool.

Mounting

The SID can be mounted like a standard cutout, directly on a pole for use as a disconnect between overhead and underground lines, or as a visible disconnect for maintenance of line equipment. This standard cutout type design allows for ease of installation with a clear indication of its position.

The SID can be mounted in the following scenarios:

- Single or double crossarm underhung
- Crossarm similar to a cutout
- Crossarm vertically
- Riser pole application
- Pole mount extended angle

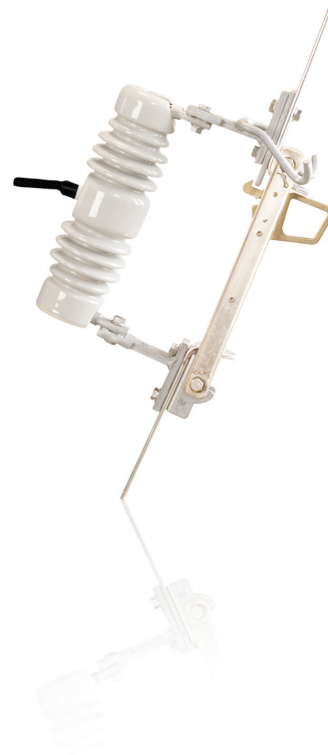

Outline drawing

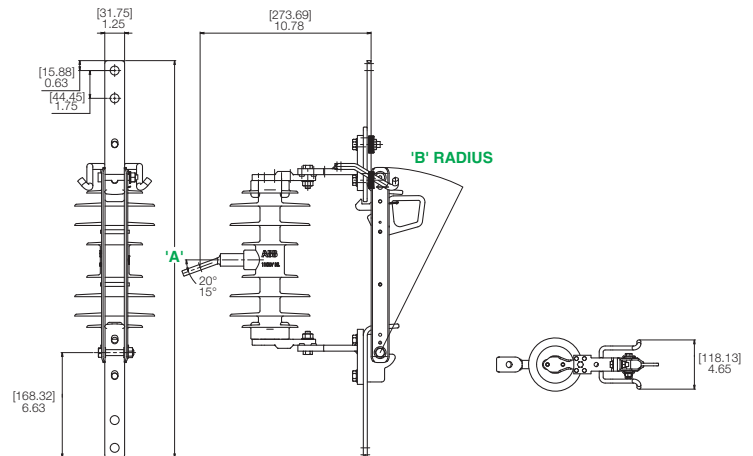

Unit dimensions

Type	Voltage rating (kV)	BIL (kV)	Dimension A		B radius		Creep	
			in	mm	in	mm	in	mm
Porcelain	15.5	110	24.6	625	13.5	342	9.1	231
Silicone	15.5	110	24.6	625	13.5	342	15.0	380
Polymer concrete	15.5	110	24.6	625	13.5	342	9.1	231
Porcelain	27	125	28.0	711	16.9	429	12.8	325
Silicone	27	125	28.0	711	16.9	429	18.9	480
Polymer concrete	27	125	28.0	711	16.9	429	12.8	325
Porcelain	38	150	28.0	711	16.9	429	17.0	432
Silicone	38	150	28.0	711	16.9	429	23.6	600

Weights

Voltage class (kV)	BIL (kV)	Continuous current (A)	Porcelain		Polymer concrete		Silicone	
			lbs	kg	lbs	kg	lbs	kg
15.5	110	600	14.7	6.7	14.1	6.4	10.9	4.9
15.5	110	900	15.6	7.1	15.0	6.8	12.0	5.4
27	125	600	18.4	8.3	17.6	8.0	13.1	5.9
27	125	900	19.3	8.8	18.5	8.4	14.0	6.4
38	150	600	25.2	11.4	-	-	19.9	9.0
38	150	900	26.1	11.8	-	-	20.8	9.4

Ratings

Maximum voltage (kV)	BIL (kV)	Continuous current (A)	Peak withstand current (kA Asym)
15.5	110	600	65
27	125	600	65
38	150	600	65
15.5	110	900	65
27	125	900	65
38	150	900	65

Selection guide

Description	Code	Definition
Switch type	D	Type SID Switch
	1	15 kV, 110 kV BIL, 9.1" creep (279C075)
	2	27 kV, 125 kV BIL, 12.8" creep (279C342)
	4	27 kV, 150 kV BIL, 18" creep (279C341)
Max kV, BIL	5	38 kV, 150 kV BIL, 18" creep (279C341)
	6	38 kV, 150 kV BIL, 600 mm creep silicone
	7	38 kV, 170 kV BIL, 26" creep porcelain (8433C39)
	9	38 kV, 170 kV BIL, 30" creep porcelain (5853C96)
	N	No stop
Blade stop	R	90° stop
	B	160° stop
Terminal connectors	A	NEMA 2-hole with captured 0.5" hardware (galvanized)
	C	NEMA 2-hole with two-piece clamshell #2-500MCM (10013A44G01)
	D	NEMA 2-hole with double eyebolt terminal #2-350MCM
	H	NEMA 2-hole with two-piece clamshell 4/0-500MCM (10013A44G02)
	T	NEMA 2-hole pad – standard
Brackets	B	NEMA B bracket only (403A101G03)
	E	Extended bracket (367C802G04)
	U	U pole mounting bracket (403A101G03 and 3905B11H02)
Hooks	N	No bracket
	L	Galvanized steel hooks
Continuous current	600	600 amperes
	900	900 amperes
Unused	0	Space holder for future options
Unused	0	Space holder for future options
Insulator	A	Porcelain
	J	Silicone
	Z	Polymer concrete

Example: D1RHNL600A = SID, 15 kV, 110 kV BIL, 90° stop, NEMA 2-hole pads with clamshell 4/0-500MCM, no bracket, galvanized hooks, 600 A, no special options

SID mounting configurations

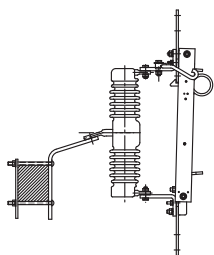

Crossarm, extended angle

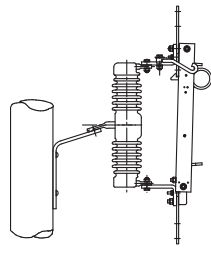

Pole mount extended angle

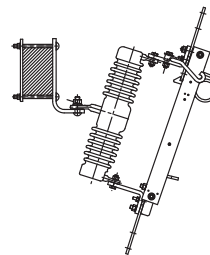

NEMA "B"

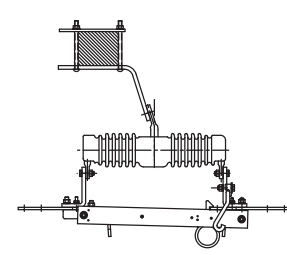

Underhung

LSID disconnect switch

Product features

- Offered in two voltage classes and four BIL sizes. Each voltage class is designed for 600 A or 900 A continuous load with 65 kA peak (40 kA momentary) rating.
- Silicone, polymer concrete, or porcelain insulators available
- Lightweight alternative to double insulator disconnect switch
- Underhung or polemount mounting
- All testing is in accordance with IEEE 37.34

Description

The LSID disconnect switch is a single insulator disconnect with self-contained loadbreak capabilities, a double-blade door, and two 2-hole extended NEMA pad terminals. The LSID is a lightweight, flexible alternative to the commonly used double insulator design. In addition, the LSID disconnect incorporates the ABB quality approach to cutout design.

Application

The LSID is used as a disconnect on overhead distribution feeders and in outdoor distribution substations. It is also used to provide a visible break point for maintenance personnel. The self-contained loadbreak concept enables the utility to interrupt load current by operating the switch with a simple hookstick.

Mounting

The LSID can be mounted like a standard cutout, directly on a pole for use as a disconnect between overhead and underground lines, or as a visible disconnect for maintenance of line equipment. This standard cutout design provides a clear indication of its position and allows for easy installation.

An optional mounting kit is available that allows for a variety of mounting scenarios:

- Single or double crossarm underhung
- Crossarm similar to a cutout
- Crossarm vertically
- Riser pole application



Outline drawing

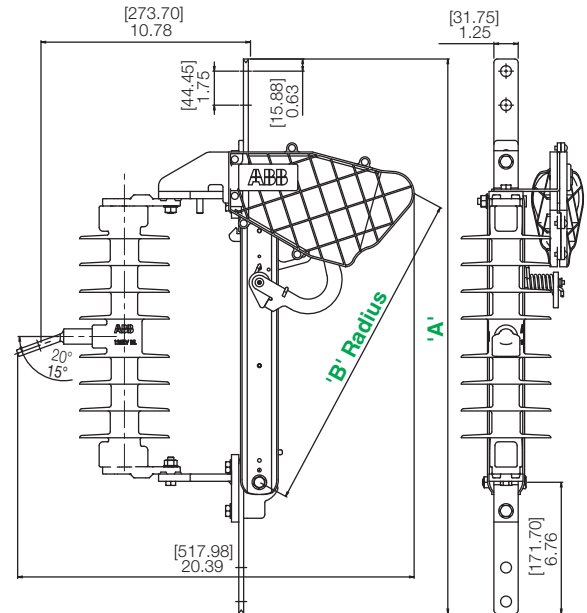

Unit dimensions

Type	Voltage rating (kV)	BIL (kV)	Dimension A		B radius		Creep	
			in	mm	in	mm	in	mm
Porcelain	15.5	110	24.6	625	13.5	342	9.1	231
Silicone	15.5	110	24.6	625	13.5	342	15.0	380
Polymer concrete	15.5	110	24.6	625	13.5	342	9.1	231
Porcelain	15/27	125	28.0	711	16.9	429	12.8	325
Silicone	15/27	125	28.0	711	16.9	429	18.9	480
Polymer concrete	15/27	125	28.0	711	16.9	429	12.8	325
Porcelain	15/27	150	28.0	711	16.9	429	17.0	432
Silicone	15/27	150	28.0	711	16.9	429	23.6	600

Weights

Voltage class (kV)	BIL (kV)	Continuous current (A)	Porcelain		Polymer concrete		Silicone	
			lbs	kg	lbs	kg	lbs	kg
15.5	110	600	16.7	7.6	15.8	7.2	12.8	5.8
15/27	125	600	20.4	9.3	19.6	8.9	15.1	6.8
15/27	150	600	27.2	12.3	-	-	21.9	9.9
15.5	110	900	17.6	8.0	16.7	7.6	13.7	6.2
15/27	125	900	21.3	9.7	20.5	9.3	16.0	7.3
15/27	150	900	28.1	12.7	-	-	22.8	10.3

Ratings

Maximum voltage (kV)	BIL (kV)	Continuous current (A)	Loadbreak current (A)	Peak withstand current (kA Asym)
15.5	110	600	600	65
15/27	125	600	600	65
15/27	150	600	600	65
15.5	110	900	600	65
15/27	125	900	600	65
15/27	150	900	600	65

Selection guide

Description	Code	Definition
Switch type	B	Type LSID loadbreak switch
Max kV, BIL	1	15 kV, 110 kV BIL, 9.1" creep (279C075)
	2	15/27 kV, 125 kV BIL, 12.8" creep (279C342)
	4	15/27 kV, 150 kV BIL, 18" creep (279C341)
	7	15/27 kV, 170 kV BIL, 26" creep (8433C39)
Blade stop	N	No stop
	R	90° stop
	B	160° stop
Terminal connectors	A	NEMA 2-hole with captured 0.5" hardware (galvanized)
	C	NEMA 2-hole with two-piece clamshell #2-500MCM (10013A44G01)
	D	NEMA 2-hole with double eyebolt terminal #2-350MCM
	H	NEMA 2-hole with two-piece clamshell 4/0-500MCM (10013A44G02)
	T	NEMA 2-hole pad – standard
Brackets	B	NEMA B bracket only (403A101G03)
	E	Extended bracket (367C802G04)
	U	U pole mounting bracket (403A101G03 and 3905B11H02)
Unused	N	No bracket
Continuous current/loadbreak	6	600 ampere continuous/600 amperes MAX loadbreak
	9	900 ampere continuous/600 amperes MAX loadbreak
Unused	N	Space holder for future options
Unused	N	Space holder for future options
Insulators	A	Porcelain
	J	Silicone
	Z	Polymer concrete

Example: B2NCBN600J = LSID, 27 kV, 125 kV BIL, no stop, NEMA 2-hole pads with clamshell 2-500MCM, NEMA B bracket, 600 A, silicone insulator

LSID mounting configurations

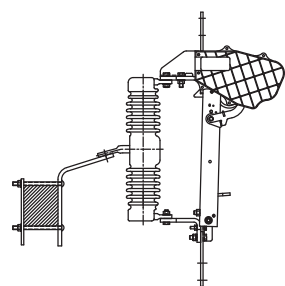

Extended angle

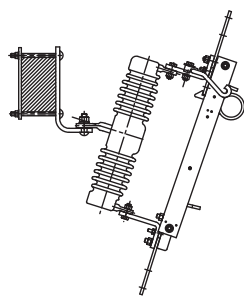

NEMA "B"

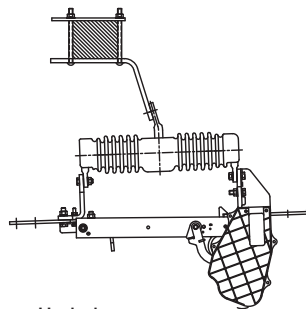

Underhung

ITD inline tension disconnect switch

Product features

- Silicone insulator provides extra leakage distance and BIL ratings to ensure inline switches are not the flashover point
- Blades are copper with stainless steel blade stops
- Loadbreak hooks made of galvanized steel for corrosion protection, to be used with loadbreak tool
- Standard two-hole NEMA plated pad or optional two-piece parallel groove
- All testing is in accordance with IEEE 37.34

Description

The ITD inline tension disconnect is a hookstick-operated switch used to manually switch de-energized or parallel circuits of overhead distribution lines rated 15 through 38 kV, 150 and 200 kV BIL. The ITD is installed directly in the line and is used to sectionalize the circuit. Switches are selected by continuous current and voltage ratings. The ITD is rated for 600 and 900 A continuous current and 65 kA peak withstand current (40 kA momentary).

Operation

All ITD disconnect switches include loadbreak hooks. Use the appropriate loadbreak device to open the switch under load. The pull-ring can be utilized for easy opening and ice breaking. The hook portion of the contact-casting matches the blade latch for positive closure.

Blade operation

A blade stop limits the blade range of motion to the 90° and 160° positions, and a latch prevents the switch from opening under high momentary current.

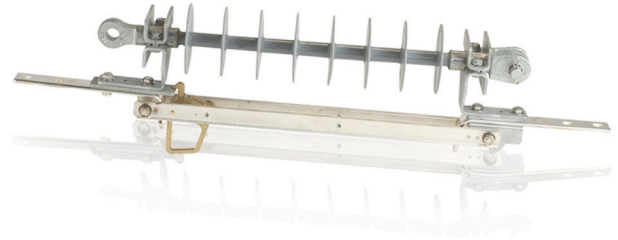

ITD mounting configuration

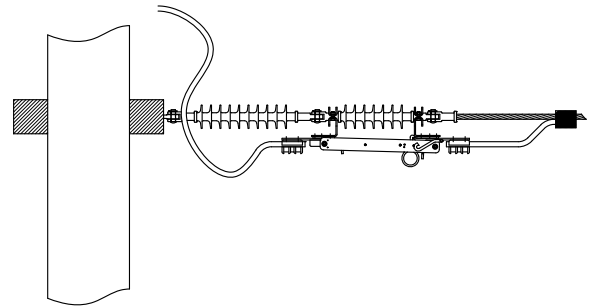

Insulator details

Voltage class (kV)	BIL (kV)	Creep Silicone	
		(in)	(mm)
15 & 27	150	23.23	590
27 & 38	200	39.00	991

Ratings

Maximum voltage (kV)	BIL (kV)	Continuous current (A)	Peak withstand current (kA Asym)
15 & 27	150	600/900	65
27 & 38	200	600/900	65

Selection guide

Description	Code	Definition
Switch type	T	Type ITD switch
Max kV, BIL	3	38 kV, 200 kV BIL
	5	27 kV, 150 kV BIL
Blade stop	N	No stop
	A	90° stop
	B	160° stop
Terminal connectors	A	NEMA 2-hole with captured 0.5" hardware (galvanized)
	C	NEMA 2-hole with two-piece clamshell #2-500MCM (10013A44G01)
	D	NEMA 2-hole with double eyebolt terminal (#2-350 MCM)
	N	NEMA 2-hole pad – standard
	H	NEMA 2-hole with two-piece clamshell 4/0-500MCM (10013A44G02)
Insulator	A	Tongue/tongue (TT), silicone
	B	Clevis/clevis (CC), silicone
	M	Tongue/clevis (TC), tongue at hinge end of switch, silicone
Unused	N	Tongue/clevis (TC), clevis at hinge end of switch, silicone
	N	Space holder for future options
Continuous current	6	600 amperes
	9	900 amperes
Specials	0	None
Unused	N	Space holder for future options
Unused	N	Space holder for future options

Example: T5NCNN9000 = ITD, 27 kV, 150 kV BIL, no stop, two-piece clamshell #2-500MCM, tongue/clevis silicone insulator, 900 A, no specials

Outline drawing

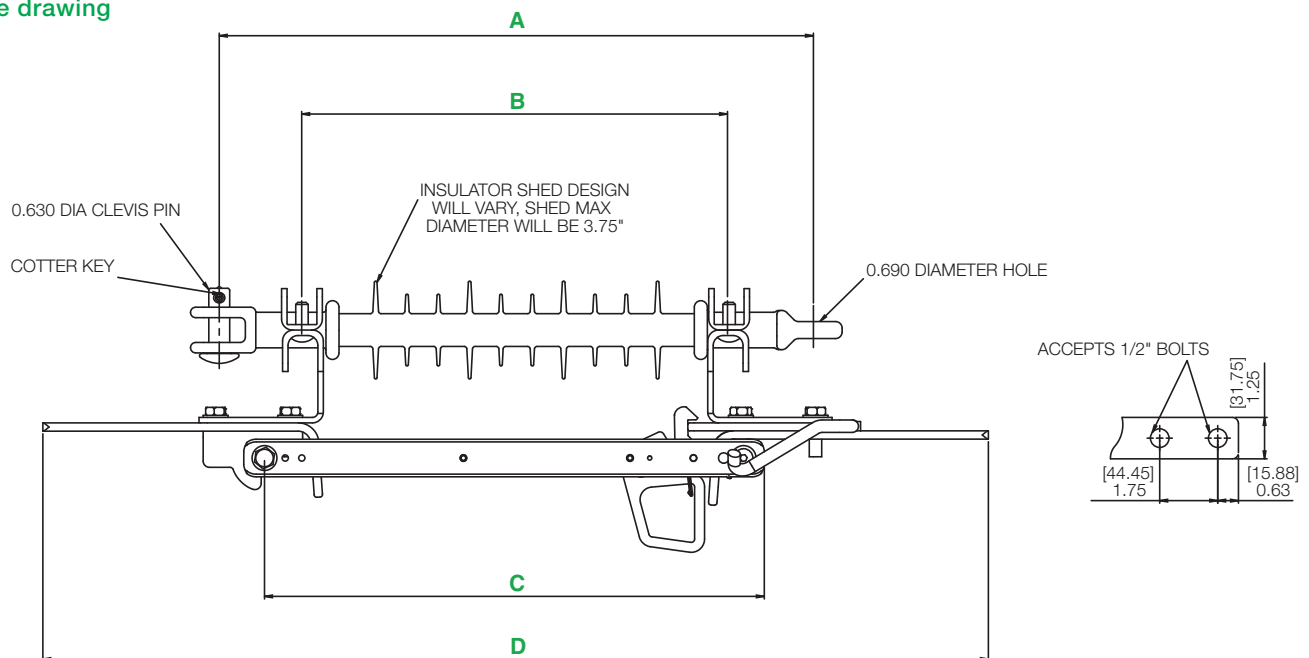

Unit dimensions

Voltage class (kV)	BIL (kV)	A		B		C		D		Silicone weight	
		(in)	(mm)	(in)	(mm)	(in)	(mm)	(in)	(mm)	(lb)	(kg)
15 & 27	150	17.92	455	12.94	326	15.08	383	28.54	725	11.0	5
27 & 38	200	20.70	526	17.26	438	19.67	500	33.13	841	14.0	6

Contact us

ABB Inc.

Medium Voltage Distribution Components

406 Banner Ave.

Greensboro, NC 27401

Phone: +1 336 275-7310

Fax: +1 336 275-1965

www.abb.com/mediumvoltage

Note:

We reserve the right to make technical changes or modify the contents of this document without prior notice. With regard to purchase orders, the agreed particulars shall prevail. ABB does not accept any responsibility whatsoever for potential errors or possible lack of information in this document. We reserve all rights in this document and in the subject matter and illustrations contained therein. Any reproduction—in whole or in parts—is forbidden without ABB's prior written consent.

Copyright 2010 ABB.

All rights reserved.